

MOBILITY ENGINEERING

AUTOMOTIVE, AEROSPACE, OFF-HIGHWAY

A quarterly publication of **SAE** INTERNATIONAL and **SAE INDIA**

DECEMBER 2013

**FIRST
ISSUE**

SIMCOMVEC Preview

Safe, green, and connected



Low-cost Datsuns from Chennai

New surface engineering technologies

**Q&A with Mahindra & Mahindra's
Executive Director & President**

E-mobility in India



MX150™ Interconnects

HIGH-PERFORMANCE INTERCONNECT TECHNOLOGY > FOR TOMORROW'S AUTOMOTIVE INNOVATION

Leveraging our expertise in interconnect technology, Molex is powering the future of the Connected Vehicle segment with the MX150™ interconnect system. Offering a reduced package size, it is ideal for SAE- and ISO-style wire in single- and dual-row configurations up to 22.0A.

For standard and custom solutions that enable innovation and enhance the on-board experience, turn to Molex. We're committed to automotive innovation — from the inside out.



See how we can enhance your designs:
molex.com/me/mx150.html

molex®
one company > a world of innovation

CONTENTS

Volume 1, Number 1

Features

46 Technologies for safe, green, and connected vehicles

SIMCOMVEC PREVIEW

SIMCOMVEC 2013 will feature 40 technical sessions, an exhibition, and a ride-and-drive.

47 Q&A with Dr. Pawan Goenka

INTERVIEW

The Executive Director & President – Automotive & Farm Equipment Sectors, Mahindra & Mahindra Ltd. answers questions on a range of subjects such as auto fuel efficiency, emissions, alternative fuels, safety, telematics, manufacturing, and sustainability.

50 Advances in surface engineering

MATERIALS

Newer materials with improved properties can enhance the properties of the working surfaces of cylinder components for the demands of increased temperatures, pressures, and corrosive atmospheres and still satisfy performance and life requirements.

54 E-mobility opportunities in the Indian ecosphere

AUTOMOTIVE ELECTRIFICATION

The Prime Minister of India in January 2013 unveiled the National Mission on Electric Mobility and formed a National Board of Electric Mobility to fast track e-mobility for India through industry-government partnerships.

56 Building cars From Legos

AUTOMOTIVE DESIGN & MANUFACTURING

The new Nissan/Renault plant for new low-cost Datsun cars in Chennai provides an opportunity to explore a tale of two modular system approaches.

60 Mobility in 21st Century India

STUDENT PERSPECTIVE

India's rapidly growing population has made transportation systems unable to effectively keep up with demand, losing the country untold man hours and wasting money.

64 Low-cost instrument clusters

AUTOMOTIVE INTERIORS

A Delphi expert proposes a design strategy to help overcome challenges for manufacturability of automotive displays suited for emerging markets.



follow us @SAEAutoMag

69 Metals make a comeback

AEROSPACE MATERIALS

A look at how new metallic and hybrid materials are competing with carbon composites for a continuing role in aerospace manufacturing.

74 High hopes or just dreaming?

AIRCRAFT

A look at how Asia's aircraft manufacturers are trying to break into new markets to challenge the status quo.

79 Sensitive to safety

OFF-HIGHWAY ELECTRONICS

A growing number of digital sensors are among the tools being used to make sure failures are rare and injuries are even more infrequent.

83 Simulating off-highway hybrids

OFF-HIGHWAY ELECTRONICS | SIMULATION

With customers squeezed by fuel costs, off-highway OEMs are showing some interest in developing hybrid equipment. CAE simulation tools are needed because of lack of experience with such devices. Their functional complexity requires control system simulation throughout their lives.



Cover

The U-2523 T heavy commercial truck is one of the latest offerings from Ashok Leyland, the event sponsor of SIMCOMVEC, the joint effort from SAEINDIA and SAE International (see page 46).



CONTENTS

Departments

4 Editorial

Mobility Engineering to address transportation challenges

6 Focus

Welcome to the first issue of *Mobility Engineering*

8 Messages from Industry

SAEINDIA evolves with *Mobility Engineering*

10 SAEINDIA News

- 10 Update on Virtual SUPRA SAEINDIA
- 10 SAEINDIA and membership
- 11 Virtual Baja-2014 qualifying

12 Industry News

- 12 Ashok Leyland sells Detroit-based testing and engineering company
- 12 Tata Steel to build ultra-modern furnace to make aerospace steels
- 12 Mahindra Aerospace opens new aerostructures facility in Bangalore
- 14 Relan forms joint venture with Toyota Boshoku
- 14 VECV produces Euro 6 engines at technologically advanced Indian plant
- 14 Dana supplies axles for new M&M platform

16 Tech Report

- 16 GM's new 1.0-L turbocharged triple aims for benchmark NVH **AUTOMOTIVE POWERTRAIN**
- 18 The case for alternative fuels **AUTOMOTIVE ENERGY**
- 20 Energy recovery choices for commercial vehicles **TRUCK POWERTRAIN | ENERGY**
- 22 Customers get fast payback from extra cost of Cat hybrid excavator **OFF-HIGHWAY ENERGY**

- 24 Testing new materials and technology for the aerospace industry **AEROSPACE PROPULSION | MATERIALS**

- 27 Why VW is anticipating trouble ahead **AUTOMOTIVE ELECTRONICS**

- 29 A touch of simplicity in the cockpit **AEROSPACE AVIONICS**

- 30 CGT's new coverstock exceeds 40% sustainable content **AUTOMOTIVE INTERIORS**

- 32 Lightweight carbon-fiber and SMC body panels under development **AUTOMOTIVE BODY**

- 35 Grede offers iron as lightweighting option **TRUCK MATERIALS**

- 38 Federal-Mogul upgrades simulation and testing to meet engine downsizing **AUTOMOTIVE SIMULATION**

- 40 Modeling and simulating hydraulic circuits **OFF-HIGHWAY HYDRAULICS | SIMULATION**

- 43 Fine-tuning vibro-acoustic countermeasures in a turboprop aircraft **AEROSPACE TESTING**

87 Global Vehicles

- 87 Kubota goes deluxe with two new models for its M-Series
- 88 Scania employs simulation to produce customer-specific vehicles
- 90 Doosan DX140LCR excavator features reduced tail swing
- 90 ABB 'flash charges' electric bus in 15 s
- 92 Deere's 2014 8R tractors get more powerful and a new cab
- 94 2014 Sprinter gets upgrades in growing commercial van segment

96 Q&A

Finding common ground among automotive, aerospace, and CV electronics

© SAEINDIA and SAE INTERNATIONAL reserves all rights.

No part of this publication and/or website may be reproduced, stored in a retrieval system or transmitted in any form without prior written permission of the Publisher. Permission is only deemed valid if approval is in writing. SAEINDIA and SAE International buys all rights to contributions, text and images, unless previously agreed to in writing. In case of address/addressee not found, return to SAE INDIA, No 1/17Ceebros Arcade, 3rd Cross, Kasturba Nagar, Chennai -600 020. Telefax: 91-44-2441-1904, Phone: 91-44-4215 2280.

SAE
INTERNATIONAL

SAE INDIA

Published by : SAEINDIA, 1/17, 3rd Cross, Kasturba Nagar, Adyar, Chennai - 600 020.

Printed at : Hi-tech Offset Private Ltd., 11, Srinivasa Nagar Main Road, Koyambedu, Chennai - 600 107.

MULTIBODY DYNAMICS: A swashplate mechanism is used to control the orientation of helicopter rotor blades.

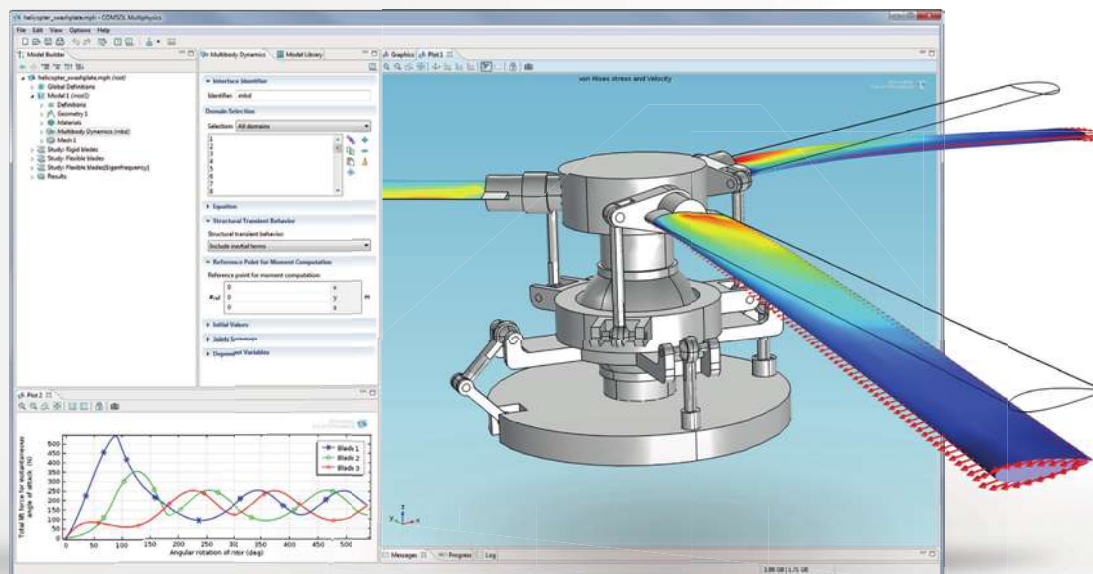

Verify and optimize your designs with COMSOL Multiphysics®

Multiphysics tools let you build simulations that accurately replicate the important characteristics of your designs. The key is the ability to include all physical effects that exist in the real world. To learn more about COMSOL Multiphysics, visit www.comsol.co.in/introvideo

Product Suite

COMSOL Multiphysics

ELECTRICAL
AC/DC Module
RF Module
Wave Optics Module
MEMS Module
Plasma Module
Semiconductor Module

MECHANICAL
Heat Transfer Module
Structural Mechanics Module
Nonlinear Structural Materials Module
Geomechanics Module
Fatigue Module
Multibody Dynamics Module
Acoustics Module

FLUID
CFD Module
Microfluidics Module
Subsurface Flow Module
Pipe Flow Module
Molecular Flow Module

CHEMICAL
Chemical Reaction Engineering Module
Batteries & Fuel Cells Module
Electrodeposition Module
Corrosion Module
Electrochemistry Module

MULTIPURPOSE
Optimization Module
Material Library
Particle Tracing Module

INTERFACING
LiveLink™ for MATLAB®
LiveLink™ for Excel®
CAD Import Module
ECAD Import Module
LiveLink™ for SolidWorks®
LiveLink™ for SpaceClaim®
LiveLink™ for Inventor®
LiveLink™ for AutoCAD®
LiveLink™ for Creo™ Parametric
LiveLink™ for Pro/ENGINEER®
LiveLink™ for Solid Edge®
File Import for CATIA® V5





EDITORIAL

Kevin Jost
Editorial Director
kevin@sae.org

Asit Barma
SAE India Editor

C V Raman
ED, MSIL
CV.Raman@maruti.co.in

Arun Jaura
VP, SAEINDIA
arunjaura@gmail.com

Bala Bharadvaj
MD, Boeing R & T
bala.k.bharadvaj@boeing.com

Mathew Abraham
Sr. GM, Mahindra
ABRAHAM.MATHEW@mahindra.com

Nitin Ranade
VP, Mahindra
ranade.nitin@mahindra.com

Sudhakar Shenoy
Advisor, John Deere
shenoy.sudhakar@rediffmail.com

Venkat Srinivas
Special Director, Ashok Leyland
venkat.srinivas@ashokleyland.com

Venugopal
CVRDE
venutrans@yahoo.com

Jean L. Broge
Managing Editor
jbroge@sae.org

Lindsay Brooke
Senior Editor
abrooke@sae.org

Patrick Ponticel
Associate Editor
ponticel@sae.org

Ryan Gehm
Associate Editor
rgehms@sae.org

Matt Monaghan
Assistant Editor
mmonaghan@sae.org

Lisa Arrigo
Custom Electronic
Products Editor
larrigo@sae.org

Kami Buchholz
Detroit Editor

Stuart Birch
European Editor

Jack Yamaguchi
Asian Editor

Contributors
Steven Ashley, Dan Carney,
Terry Costlow, Richard Gardner,
John Kendall, Bruce Morey,
Paul Weissler, Jenny Hessler,
Jennifer Shuttleworth,
Linda Trego

DESIGN

Wayne Silvonc
Art Director

Brian Fell
Senior Designer

Ryan Pristow
Senior Designer

William L. Schall
Graphic Artist

Lucy Matyjaszczyk
Graphic Artist

SALES & MARKETING

K. Shriramchandran
SAE India
No.1/17, Ceebros Arcade
3rd Cross Kasturba Nagar
Chennai
India 600 020
(T)91-44-42152280
(E) ddg@saeindia.org

Marcie L. Hineman
Global Field Sales Manager
+1.724.772.4074
hineman@sae.org

Mobility Engineering to address transportation challenges

SAEINDIA and **SAE International** have big plans for our Indian members and the Indian transportation engineering community. This new magazine, *Mobility Engineering*, and the industry show where it launches, SIMCOMVEC 2013, are the prime evidence.

This issue of *Mobility Engineering* will be the first of many, with four issues planned in 2014 (see table). Our plans are for the publication to be the best at covering automotive, aerospace, and off-highway engineering trends both in India and from around the world, tapping into the global content creation resources at our disposal. In this issue, we bring to you a nice mix of content from top executives in the industry as well as those just entering the industry.

An overview of the industry is provided from a newcomer's perspective in the feature titled

VEC 2013 combines the 8th SAEINDIA International Mobility Conference with the inaugural Commercial Vehicle Engineering Congress India, and is being held at the Chennai Trade Centre over 4-7 December 2013. Forty technical sessions will examine critical topics for the on-road and off-road engineering community.

Other key articles contributed by the top technical minds from the Indian industry include:

- *Q&A with Dr. Pawan Goenka*: The Executive Director & President – Automotive & Farm Equipment Sectors, **Mahindra & Mahindra Ltd.**, answers many wide-ranging questions on auto fuel efficiency, emissions, alt fuels, safety, telematics, manufacturing, and sustainability.
- *Advances in surface engineering*: Dr. R. Mahadevan of **India Pistons Limited** writes about how newer materials with improved prop-

March	June	September	December
AUTOMOTIVE	AUTOMOTIVE	AUTOMOTIVE	AUTOMOTIVE
- Powertrain: Hybrid & Electric Drives - Body	- Electronics: Active Safety - Energy: Alternative Fuels	- Body & Chassis: Vehicle Dynamics - Systems Engineering/Integration	- Electronics: Autonomous Vehicles - Simulation: Computer-aided Engineering
AEROSPACE	AEROSPACE	AEROSPACE	AEROSPACE
Avionics: Active Safety	Propulsion: Energy Storage	Testing & Simulation: Aerodynamics	Manufacturing & Materials: Composites
OFF-HIGHWAY	OFF-HIGHWAY	OFF-HIGHWAY	OFF-HIGHWAY
Electronics: Powertrain Management	Powertrain & Energy: Alternative Powertrains	Electronics: Telematics	Hydraulics: Electrohydraulic Advances

Mobility in 21st Century India. The Indian transportation industry is one of the largest and most diverse, attempting to fulfill the needs of 1.24 billion people. From 2011-12, the transport sector contributed 6.8% to the nation's GDP (road transport alone accounts for 5.5%), with a targeted growth of 10% per year.

As of 2010, India is home to 40 million passenger vehicles. According to the **Society of Indian Automobile Manufacturers**, annual vehicle sales are projected to increase to 5 million per year by 2015 and more than 9 million per year by 2020. By 2050, the country is expected to top 611 million vehicles on the nation's roads.

SIMCOMVEC 2013 will address many of the industry's technology challenges from the commercial and off-highway vehicle perspective, as highlighted in our SIMCOMVEC preview headlined with the event's theme, *Technologies for safe, green, and connected vehicles*. SIMCOM-

erties can enhance the properties of the working surfaces of cylinder components for the demands of increased temperatures, pressures, and corrosive atmospheres and still satisfy performance and life requirements.

• *E-mobility opportunities in the Indian eco-sphere*: Dr. Arun Jaura, a member of the Board of Directors, SAE International; Chairman, Automotive Board, SAEINDIA; and MD & Founder, **TRAKTION Management Services Pvt. Ltd.**, talks about the challenges involved in addressing the Prime Minister of India's National Mission on Electric Mobility and National Board of Electric Mobility to fast-track e-mobility for India through industry-government partnerships.

We hope you enjoy this first issue. Let us know what you think. We are always looking for ideas on future articles. If you are interested in contributing to future issues, email me at kevin@sae.org.



Access to expertise you can trust.

How can you win in today's marketplace? Do you have what you need to set your company apart?

Work closely with Lubrizol and you will have access to a higher level of additive and market expertise, the widest product coverage and the broadest range of capabilities in the industry.



*Visit Lubrizol.com/successtogether
to experience Success Together.*

Lubrizol



© 2013 The Lubrizol Corporation.
All rights reserved. 130004

Welcome to the first issue of *Mobility Engineering*

I am extremely happy to learn that the first issue of *Mobility Engineering*—a joint publication of **SAEINDIA** and **SAE International**—would be released in conjunction with the momentous event of SIMCOMVEC, which combines SAEINDIA's 8th International Mobility Conference with SAE International's 1st Commercial Vehicle Congress in India. The publication is a culmination of a series of initiatives launched consequent to the Memorandum of Understanding signed with SAE International for meaningful collaboration in serving the mobility community towards knowledge enrichment and global networking.



We have had very successful workshops with international experts on standards for the automotive industry followed by those for the aerospace industry that were very well received by mobility professionals endeavoring to constantly upgrade quality standards conforming to global benchmarks.

We were indeed overwhelmed with the support from the industry and active participation in presenting the Indian perspective on standards indicating possibilities of working together in the future to evolve standards that will benefit and impact the industry in the global scenario.

We have also had international experts from SAE conducting lecture series in India in the past six-nine months that struck the right chord with professionals from industry who

took part with keen interest in large numbers. The sessions were interactive, providing ample scope for learning the best industry practices.

The Indian automotive industry is going through a cyclical downturn owing to global impacts but has shown remarkable resilience in weathering the storm buoyed by domestic demand. The commercial vehicle industry is making rapid progress with internationally renowned brands setting up plants in India while eyeing global markets. The aerospace domain is slowly maturing, with many of the multinational leaders setting up shop to partake in Indian aviation business growth with offset facilities being the prerequisite to secure business for commercial and defense requirements of the country.

In this context, *Mobility Engineering* magazine will bring the choicest collection of articles on all the three verticals with increasing contribution from Indian experts over a period of time. It is aiming to become a handbook, reference guide, and effective tool for knowledge dissemination for mobility professionals.

BAJA SAEINDIA and SUPRA SAEINDIA have become greatly sought-after events with huge participation from engineering educational institutions in the country, and industry has also lent admirable support by sponsoring various parts of the event and by hiring the deserving team members by recruitment at the event site.

SAEINDIA is conscious of its role to address issues and concerns affecting its stakeholders and wants to build a healthy ecosystem conducive to usher in employable engineers who can contribute to industry with a minimal gestation period for knowledge dissemination and skills enhancement.

I warmly congratulate the Publications Board headed by Asit Barma and Scott Sward and his team from SAE International who have made the launch of *Mobility Engineering* possible with high-quality content and pleasing aesthetics rising to the lofty standards of SAE.

I am sure this magazine will be a harbinger of success, with many more programs like webinar and webcast programs that are on the schedule in 2014.

Best Wishes,
Mr. Shrikant R. Marathe
President, SAEINDIA

SAE INDIA BOARD OF DIRECTORS

Mr. Shrikant R. Marathe
President

Mr. R. Dayal
Immediate Past President

Dr. Aravind S. Bharadwaj
Sr. Vice President & Chairman,
Finance Board

Dr. R. K. Malhotra
Vice President & Chairman, Meeting
& Exposition Board

Dr. Bala K. Bharadvaj
Vice President & Chairman,
Aerospace Board

Dr. Arun Jaura
Vice President & Chairman,
Automotive Board

Mr. I. V. Rao
Chairman, Membership Board

Mr. Asit K. Barma
Chairman, Publication Board &
Web/Media

Mr. C. V. Raman
Vice Chairman, Publication Board &
Web/Media

Mr. Ramesh S. Pasarija
Secretary

Ms. Pamela Tikku
Joint Secretary & Chairman, Section
Board

Dr. G. Nagarajan
Treasurer & Vice Chairman, Finance
Board

Mr. G. Vijayan
Joint Treasurer & Member, Finance
Board

Dr. K. C. Vora
Chairman, Development Board

Prof. S. K. Gupte
Vice Chairman, Development Board

Mr. Sanjay P. Deshpande
Vice Chairman, Membership Board

Mr. Prakash V. Sardesai
Chairman, PDP Board

Dr. S. Thirumalini
Chairman, Engineering Education
Board

Mr. Devendra Bahirat
Chairman, Off-Highway Board

Mr. A. Akbar Badusha
Vice Chairman, Meeting &
Exposition Board

Representing SAE International

Dr. David. L. Schutt
Chief Executive Officer

Mr. Murli M. Iyer
Executive Advisor-Global Affairs
Office of the Chief Executive Officer

Presented by SAEINDIA Media, Communications and Publications Committee

Mr. Asit K. Barma
Chairman

Mr. C. V. Raman
Vice Chairman,

Mr. Umaanand Durai
Member

Mr. Arun Sivasubrahmanian
Member

Mr. R. Rajendran
Member

Mr. Rajesh Kumar
Member

Mr. Deepak Panda
Member

Mr. Avnish Gosain
Member

Mr. Mohit Sehgal
Member



Altair | HyperWorks®

Do you have Weight Issues related to your Product Design?



Lose Weight with Altair!

Reaching weight goals and efficient use of resources with compliance to reduced CO2 emissions can be met only with a light weight design strategy.

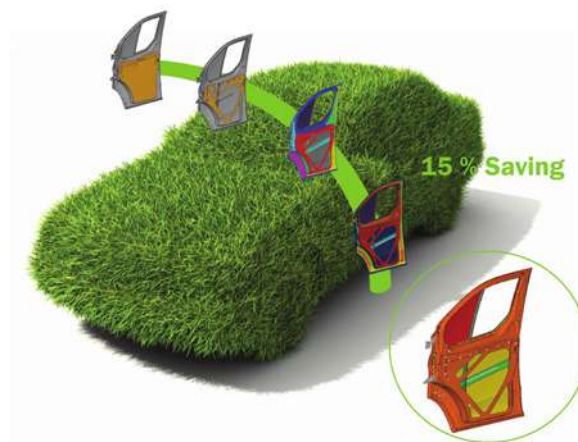

We help you to reach your Light Weight goals!

• HyperWorks Optimization Technology • Altair Weight Management

Altair Engineering India Pvt. Ltd.

Mercury 2B Block, 5th Floor, Prestige Tech Park, Sarjapur Marathahalli Outer Ring Road, Bengaluru - 560 103. INDIA

• Ph: +91.80.6629.4500 • Fax: +91.80.6629.4700 • Email: marketing@india.altair.com • www.altair-india.in • www.altairhyperworks.in • www.altairlighten.com

MESSAGES

from Industry

SAEINDIA evolves with *Mobility Engineering*

I am indeed delighted to learn that the magazine *Mobility Engineering*, a joint publication of **SAEINDIA** and **SAE International**, would be launched in conjunction with the inaugural function of SIMCOMVEC.

SAEINDIA has evolved over the past decade as a significant forum for mobility professionals and practitioners all over the country, reaching out to more than 50,000 members and growing—making it the largest affiliate of SAE International.

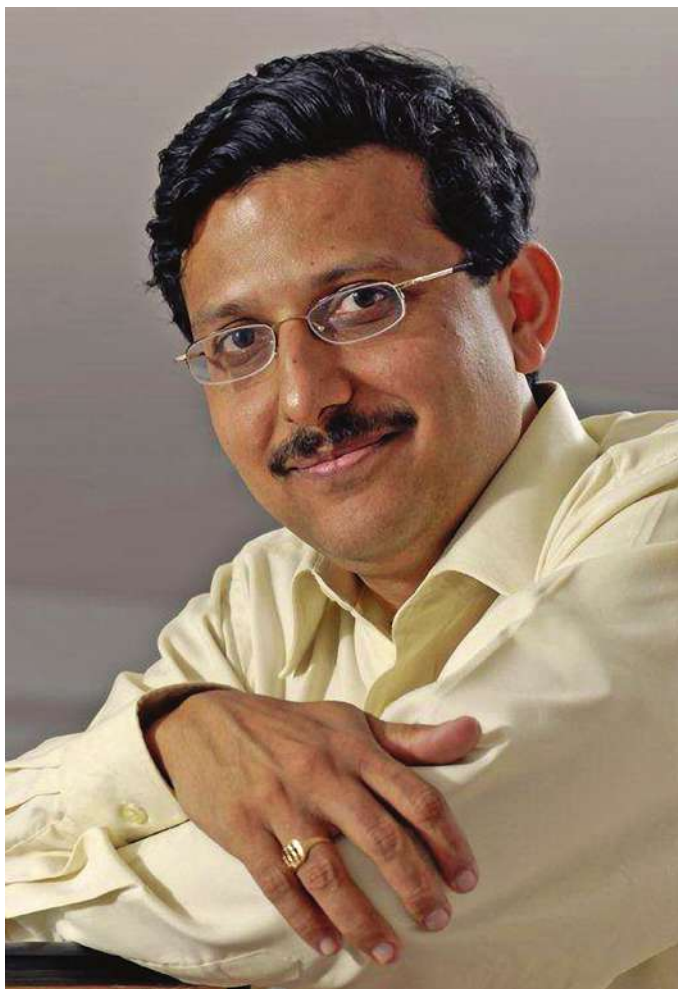

SAEINDIA programs like BAJA SAEINDIA and SUPRA SAEINDIA have caught the imagination of young engineering students, and in the past few years there has been an exponential increase in the number of teams participating in the events. There is considerable support from the industry for the teams, and sponsoring companies recruit talented engineers on the spot at the event sites.

Students have also developed practical working skills in design and development, production, welding, and fabrication—bringing about weight and cost reduction. These events have built knowledge, hands-on exposure, and teamwork skills, enabling the participants to acquire self-confidence and creative work habits infusing a passion for working in core manufacturing automobile industries. SAEINDIA has instituted special awards and prizes to recognize the outstanding skills demonstrated by the students participating in these events.

SAEINDIA's focus on cultivation of employable engineers resulted in the launch of a pilot scheme, Career Start, that was conceived and implemented by the SAEINDIA Southern Section. This initiative has been well received and appreciated by the industries, and SAEINDIA is planning to scale it up nationally to address this growing requirement of the industry, while at the same time create value for the student members.

SAEINDIA, like SAE International, is dedicated to the cause of advancement of the mobility community, with the primary objective to create opportunities for its members for lifelong learning and global networking. I believe that this magazine is a first step by SAEINDIA towards knowledge dissemination to the members. In addition, a strong professional development program is being conceived and will be rolled out shortly with an aim towards enhancing skills development opportunities for the professional mobility community at large.

SAEINDIA has expanded its reach and scope by launching the Aerospace Board in 2009 and the Off Highway Board in 2010. While the Automotive Board has been active and expanding, the two new verticals have already organized programs addressing sector-specific issues and concerns with remarkable alacrity. I expect that *Mobility Engineering* magazine will become a knowledge repository for young engineers and professionals as it will contain select articles covering all three verticals with a steady increase in content from Indian experts in all sectors.

I am sure that this magazine will become a sought-after publication by the mobility engineering community, both in industry and academia, and become a digest for professionals widening their horizon and perspective to understand the latest advancements in mobility technology.

I wish the magazine a resounding success with increased frequency and reach over the years.

Best Wishes,
Dr. Aravind Bharadwaj
Sr. Vice President, SAEINDIA

Excellence, In Farming & Beyond.

Excellence is not something that we engineer, inspect or input into our tractors. It is an innate desire to attain the best that comes from within each of us. It defines our lives at work and at home and ripples out into the world around us.

TAFE 



Cultivating The World



A US \$1.6 billion company
World's 3rd largest manufacturer of tractors
Powering farms in over 80 countries

TAFE CORPORATE COMMUNICATIONS

TAFE, Massey Ferguson & Eicher Tractors | Farm Machinery | Engines
Gears & Transmissions | Engineering Plastics | Hydraulic Pumps & Cylinders
Panel Instruments | Batteries | Vehicle Sales | Plantations

SAEINDIA

News

Update on Virtual SUPRA SAEINDIA

SUPRA SAEINDIA, a student design competition series organized by **SAEINDIA**, was first held in 2011 during the tenure of Mr. R. Dayal EO, **Maruti Suzuki India Ltd**, and Past President of SAEINDIA. This event provides a real-world engineering challenge for the

SAEINDIA student members that reflects the steps involved in the entire process from designing, building, testing, producing, and marketing a product.

SUPRA SAEINDIA starts with a qualifying event in which all the registered teams are required to present their vir-

tual design with detailed specifications complying with the defined rules. The teams selected in the virtual SUPRA qualify for the main event.

For SUPRA SAEINDIA 2011, 59 teams registered for the virtual event and 44 teams were selected for the final event held at Madras Motor Race Track Chennai from July 1 to 3, 2011. For SUPRA SAEINDIA 2012, 105 teams registered for the virtual event, and 65



SAEINDIA and membership

SAEINDIA is a strategic alliance partner of **SAE International**. It is registered as an Indian, not-for-profit engineering and scientific society dedicated to the advancement of mobility industry in India.

The first section of SAEINDIA was formed in India in the year 1994 in Pune as "Western India Section" with Dr. Pawan Goenka of **Mahindra & Mahindra** as the first Section Chair. This was soon followed by other sections in Chennai (Southern India Section), Delhi (Northern India Section), and Kolkata (Eastern India Section). In 2002, all four sections were merged to form SAE India, as an affiliate society of SAE International. Dr. K. Kumar of Maruti-Suzuki was elected as the first SAE India President.

Mr. Shrikant R. Marathe, Director, **ARAI** is the current President and Mr. R. Dayal, Executive Officer, **Maruti Suzuki India Ltd** is the immediate Past President. Currently, SAEINDIA has around 3400 Professional members and 33,000 student members.

SAEIndia members have access to state-of-art information on mobility engineering. SAEIndia offers great opportunities for networking and continuous education in the field of mobility technology and engineering through its programs and activities throughout the country. The society has a number of sections, divisions, and collegiate clubs in different parts of the country.

Members can purchase SAE technical papers at discounted prices. Members also get Technical Magazines of their choice. Members can participate in various professional development courses, job fairs, technical meetings, workshops, and conferences. They can participate in various educational activities conducted specially for professional members, engineering students and faculty members, and primary and secondary school children. Events such as SUPRA SAEINDIA, Baja SAEINDIA, EFFI Cycle, and AWIM are already very popular among the Indian student community.

teams were selected for the final event held at BIC, Noida from September 6 to 9, 2012.

For the first time, SUPRA SAEINDIA 2013 was organized around Formula Student rules. With this, students can build a vehicle to international standards and they can also participate in all International competitions with the same vehicle. For this year's event, 174 teams from 21 India states registered, which is a quantum leap, raising the event to International standards. This number included 65 teams from the South Zone, 64 Teams from the West Zone, 36 from the North Zone, and nine teams from the East Zone. This year, out of 174 teams registered, 124 teams were new, signifying the awareness, popularity, and healthy competition standards.

Virtual SUPRA SAEINDIA was held on September 20 and 21, 2013, at **KIIT**

University, Bhubaneswar, Odisha. Automotive professionals from companies like **Mahindra & Mahindra**, **Bajaj**, **Tata Motors**, **Bosch**, and **Altair**—with years of technical experience along with a team of **Federation of Motor Sports Clubs of India (FMSCI)**—were invited for judging the student presentations.

The event formally started on September 19 with a briefing of the judges by Mr. J. Balamurugan from FMSCI. Afterward, cultural events for participants were organized by KIIT, with a performance from **Kalinga Institute of Social Sciences (KISS)**, and followed by dinner for the judges and organizing committee.

Inaugural function was held on September 20. Mr. R. Dayal, Executive Officer, Maruti Suzuki India Ltd, was the Chief Guest for the event. Dr. Arun K. Jaura, Managing Director and Founder, **TRAKTON**, and Mr. Asit K. Barma, VP, **Defiance Technologies**, were distinguished Guests of Honor. Dr. S. Thirumalini HOD, Auto Engineering Department, **Amrita School of Engineering**, was the Convener of SUPRA SAEINDIA 2014. The event was started with the Lighting of Diya by distinguished guests and followed with the welcome address by Mr. Shriramchandran, Deputy Director General, SAEINDIA.

The live scoring card, launched by Guest of Honor, Mr. R. Dayal, was one of the major new developments compared with Baja & Supra Events. Teams could view their scores just after completing their presentations. Team presentations were slotted for two days. Cultural programs on Day 1 were organized by KISS.

The Chief Guest for the September 21 Closing Ceremony was Mr. Dilip C. Shenoy, Chairman & MD, **NSDC**. Dignitaries present included Mr. Arvind Pongonkar, Mr. Unni Nayar, and Dr. A. Samanta, Founder of KIIT & KISS. Results were launched by Dr. S. Thirumalini HOD, Chairperson Engineering Education Board and Convener, SUPRA SAEINDIA 2104, and Mr. J. Balamurugan, Virtual Event Convener, SUPRA SAEINDIA 2014.

Of the 169 teams participating in the virtual event, 100 qualified for the finals to be held in July 2014, at **MMRTC**, Chennai. ■

Virtual Baja-2014 qualifying

Preparations for Virtual Baja-2014 were held at **Sri Venkateshwara College Of Engineering (SVCE)**, Bangalore, on July 26 and 27, 2013. More than 320 teams from all over India participated in the virtual round, out of which 125 teams have qualified for the final event to be held in February 2014, at NATRIP Pithampur, Indore.



Inaugurated by Mr. Vinay Harne, Chairman, **SAEINDIA**, Bangalore Section, along with Dr. K. C. Vora, Deputy Director, **ARAI**, Pune; Mr. Prabhakar Reddy, Principal, SVCE; Prof. Udaya Ravi, HOD, Mechanical Dept., SVCE; Mr. Shashidhar, Chief Executive Director, SVCE; Mr. J. Munirathnam, Treasurer, SAEINDIA, Bangalore Section; and Mr. K. Shriramachandran, Deputy Director General, SAEINDIA, the backdrop for the Virtual Baja competition was set by lighting the lamp.

Engineers from various automobile companies were invited as judges. Around 350 SAEINDIA collegiate clubs from all over India took part in the competition.

Mr. M. Kannan, Secretary, SAEINDIA, Bangalore section, was presented the Achievement Award for his significant contribution effort in helping to organize the Virtual Baja-2013. ■

Industry NEWS

Ashok Leyland sells Detroit-based testing and engineering company

Ashok Leyland, the **Hinduja Group** flagship, has sold **Defiance Testing & Engineering Services** (DTE) to **Exova**, a leading provider of testing, calibration, and advisory services. Located near Detroit, DTE was acquired by Ashok Leyland in 2007 and since



DTE helped Ashok Leyland to attain new skills in testing and validation that led to reduced new-product development time and costs. Shown is the Hybus, a plug-in CNG hybrid bus.

has experienced consistent and profitable growth, according to the Indian OEM, through a combination of operational efficiency, new customer capture, and focus on adjacent sectors such as construction and off-highway, and defense. Ashok Leyland claims that DTE helped it attain new skills in testing and validation that led to reduced new-product development time and costs. DTE provides testing and engineering services to manufacturers and leading suppliers in the passenger car, light truck, bus, and military vehicle sectors. Its range of capabilities includes component and system testing, fatigue and durability validation, system simulation, and full-vehicle structural testing. Ashok Leyland's separate entity focused on IT and Engineering Services, **Defiance Technologies Ltd.**, remains unaffected by the transaction.

Tata Steel to build ultra-modern furnace to make aerospace steels

Tata Steel announced plans to build a vacuum induction melting (VIM) furnace at its Stocksbridge site in South Yorkshire, U.K., to enable it to tap into new market opportunities and develop innovative new products for the aerospace and oil and gas industries. The VIM furnace will allow Tata Steel's speciality steels business, which already supplies steel to aircraft engine and

airframe makers, to further develop relationships with its customers and expand its product portfolio. The company's speciality steels business will work with German metallurgical technology company **SMS Mevac**, a major supplier of vacuum steelmaking equipment, to build a VIM facility at Stocksbridge. The £15 million furnace is expected to be commissioned early in 2015. The VIM production route involves melting high-purity steel and alloys in a crucible furnace, and then casting the purified liquid steel into ingot molds, all within a low-pressure vacuum chamber. As the entire melting and casting operation is conducted in an oxygen-free atmosphere, the resulting steel is very clean and has very low gas content.

Mahindra Aerospace opens new aerostructures facility in Bangalore

Mahindra Aerospace recently opened its 25,000-m² aerostructures manufacturing facility at the Narsapura Industrial Estate near Bangalore. This facility has the ability to accurately craft large, complex sheet metal parts using CNC routing, stretch-forming, bladder press, heat treatment, and other specialized equipment. The facility also features five-axis CNC machining, a fully automated surface treatment line, priming and



(From left to right) **Arvind Mehra**, Executive Director and Global CEO, Mahindra Aerospace; **Anand Mahindra**, Chairman, Mahindra Group; **Hemant Luthra**, President—Mahindra Systech; and **Pedro Fuente**, COO Aernnova, Spain, at the inauguration of Mahindra Aerospace's new aerostructures facility in Bangalore.

painting capabilities for parts and assemblies, and nearly 10,000 m² of space for the manufacture of major airframe assemblies and sub-assemblies. Mahindra Aerospace also recently signed a technology partnership with the **Aernnova Group**, a Spain-based Tier 1 supplier specializing in the design and manufacture of major airframe assemblies. Aernnova and Mahindra Aerospace will work together to develop capabilities and meet market demand for mutual benefit.

Sensor IC Solutions for Today's Changing Automotive World

Motor Position Sensing

Digital sensor ICs capable of handling the wide speed range and noisy environment found in motor position applications

Engine Management

Extensive design experience has made Allegro the leading crankshaft speed and direction IC supplier to the stop/start market

Transmission Speed

Allegro's speed and direction sensing ICs incorporate advanced algorithms to ensure accurate system performance under severe conditions such as large rotational vibration

Wheel Speed Sensing

Allegro's wheel speed sensing ICs are capable of handling the harsh conditions common to ABS applications including damaged tone wheels or encoders, ferrous debris, and large temperature gradients.

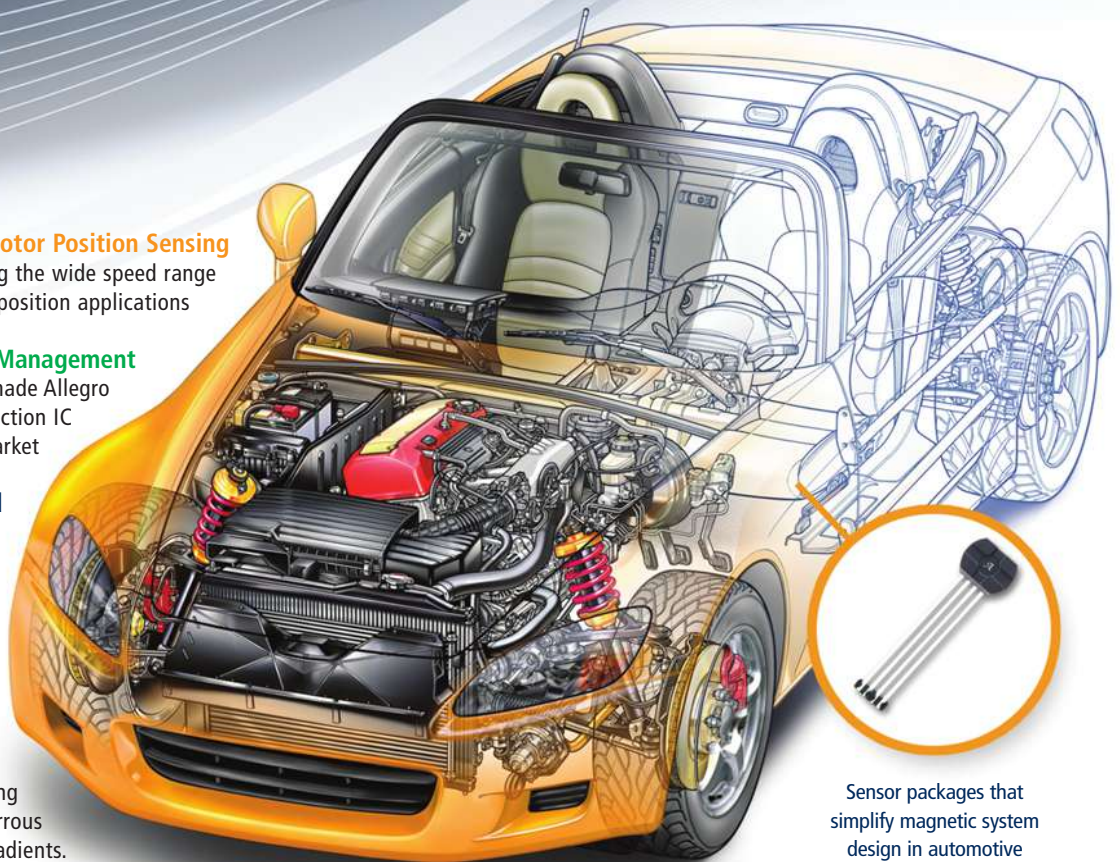

Sensor packages that simplify magnetic system design in automotive speed sensing applications.

Industry leading solutions and support

For more than 25 years, Allegro MicroSystems, LLC has designed and manufactured highly innovative sensor and power integrated circuits (ICs) for demanding, safety critical automotive applications found in transmission, engine management, braking, and other highly accurate systems. In fact, Allegro has shipped well over three billion ICs into automotive applications.

Allegro is committed to continue working alongside our customers in developing high-reliability sensor and power ICs, while local sales and technical resources ensure that our customers quickly and effectively receive high-quality service and products.

Customized features for automotive applications, including:

- Highly accurate direction detection capability
- Vibration immunity
- On-chip protection circuitry



www.allegromicro.com/camp891

115 Northeast Cutoff, Worcester, Massachusetts 01606 USA

508.853.5000

AvantGarde Solutions Private Limited

C-301, 3rd Floor, Godrej Coliseum
Behind Everard Nagar, Off Eastern Express Highway
Sion (East), Mumbai - 400022

Tel: +91-22-49222600 Fax: +91-22-24010550

E-mail: contact@avantgardesolutions.in

Industry NEWS

Relan forms joint venture with Toyota Boshoku

Two suppliers of products for vehicle interiors, India's **Relan Group** and Japan's **Toyota Boshoku**, have reached an agreement to establish a joint sales venture, called **Toyota Boshoku Relan India Private Limited**. The JV will be based in Pune City, Maharashtra State. In 2012, the companies had announced their intention to combine their collective strengths: the former's



Key players in the agreement between Relan Group and Toyota Boshoku were (from left) Sharda Motor Industries Ltd. Director Rohit Relan, Toyota Boshoku Corp. President Dr. Shuhei Toyoda, and Toyota Boshoku Asia Co., Ltd. CEO Shozo Ishikawa.

global R&D power and manufacturing capabilities, and the latter's sales and purchasing expertise. Toyota Boshoku's management hub for the Asia & Oceania region, **Toyota Boshoku Asia Co., Ltd.**, and Relan Group's automotive components company, **Sharda Motor Industries Limited**, will invest equally in the joint venture. The company has been set up with capital of 80 million Indian rupee (about \$1.4 million).

VECV produces Euro 6 engines at technologically advanced Indian plant

VE Commercial Vehicles Ltd. (VECV), a **Volvo Group** and **Eicher Motors** joint venture, is commercially producing engines at what it calls the most "technologically advanced engine manufacturing plant in India." The plant is located at Pithampur, Madhya Pradesh, with an initial capacity of 25,000 units per annum in Phase 1 at an investment of Rs 375 crores. Capacity is anticipated to eventually increase to 100,000 units per annum with an additional investment of around Rs 125 crores. The engine facility will be a hub for meeting Volvo

Group's global medium-duty engine requirements for 5- and 8-L engines. The Euro 6-compliant diesel base engines will be supplied to Volvo's plant in Venissieux, France, where they will be assembled for Euro 6 requirements. The same platform will be adapted to Euro 3 and 4 engine (BS3/BS4) technologies to meet VECV and other Volvo Group requirements in Asia. Engine platforms have a power range of 180 to 350 hp (134 to 261 kW) and provide the highest power-to-weight ratio in the Indian commercial-vehicle sector, according to VECV. The manufacturing plant is based on Volvo Group global manufacturing systems and processes, featuring a flexible final engine assembly line using automatic guided vehicles and smart cell technology.

Dana supplies axles for new M&M platform

Dana Holding Corp. announced Oct. 22 that it is expanding its business relationship with **Mahindra & Mahindra Ltd.** by supplying it with lightweight Spicer axles with AdvanTEK gears for the automaker's new platform for sport-utility vehicles and small trucks. With production expected to begin mid-2015, the

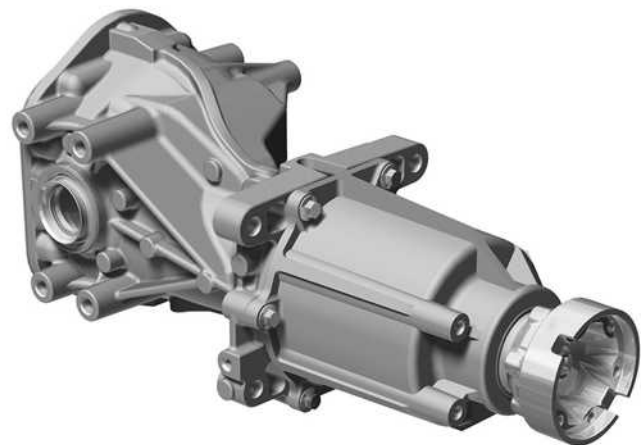

The Spicer axle shown above is representative of the kind Dana will supply to Mahindra & Mahindra.

axles will be manufactured in Chakan, India, by **Spicer India Ltd.**, a majority-owned joint-venture with **Anand Automotive Systems**. The Chakan facility produces axles, drivetrain products, and service parts for OEMs and the aftermarket in India. The banjo-style Spicer Model 180 axles are engineered to deliver enhanced efficiency and fuel economy through lower hypoid offsets. Dana says Spicer axles with AdvanTEK offer best-in-class noise, vibration, and harshness performance.

TO MOVE FORWARD IN A BETTER WAY.
BE MORE INNOVATIVE.



Moving together towards a world with smarter mobility means developing responsible technology. Unceasingly, Michelin innovates to pursue its goal by 2050, and ensures only half of the raw materials will be used in the tyre manufacturing process. Michelin also strives for minimising fuel consumption and CO₂ emissions by reducing rolling resistance and rolling noise at source. Because like you, Michelin cares about the development of responsible technology for everyone. In India, Michelin has been steadily expanding its presence in the tyre industry through multiple channels. With innovative distribution channels like TyrePlus and MTSC, partnership in the OE business with Volvo and car manufacturers like Honda and Mercedes, and with a commitment of an investment of ₹4,000 crores in 7 years, Michelin aims to strengthen the Michelin brand in India and make it synonymous with safety, technology, and innovation.

To know more, visit michelin.in through your PC or mobile. Contact us at 1800 103 6424
You can also follow us on [f/MichelinIndia](https://www.facebook.com/MichelinIndia)



TECHNOLOGY

Report

AUTOMOTIVE POWERTRAIN

GM's new 1.0-L turbocharged triple aims for benchmark NVH

In the automotive dictionary of down-sizing, the words "one" and "three" are becoming increasingly interlinked; "one" representing the engine capacity expressed in liters and "three" the number of cylinders necessary to achieve it.

N-m (122 lb-ft) from 1800 to 4700 rpm.

The new triple will drive through a new six-speed gearbox, a combination aimed at good performance with low fuel consumption and emissions. Built at GM's new Szentgotthard, Hungary, plant

and not much fun to drive. A more powerful Twin Port version came in 2003, part of GME's "O" family that heralded the current modular strategy.

Attention to NVH

Dr. Mathias Alt, Chief Engineer, Small Gasoline Engines at GME, said: "In developing this small engine, we not only set out to minimize fuel consumption and CO₂ emissions, we also wanted to demonstrate that three cylinders can be just as refined as four or more."

He explained that his development teams successfully focused on the traditional challenges of three-cylinder engines: balance, noise, and vibration. "This is a very lively and refined three-cylinder engine which doesn't compromise driving fun," he said.

Dr. Alt regards the new engine, designated 1.0-L SIDI (Spark Ignition Direct Injection) Turbo, as establishing a refinement benchmark for triples, with NVH characteristics superior to many four-cylinder units. Fuel consumption is claimed to be some 20% better than that of the 1.6-L naturally aspirated engine used in the company's Astra models.

As well as DI, continuously variable valve timing and a lightweight aluminum cylinder block are central to the engine's efficiency. GME engineers expect the new engine family to deliver CO₂ emissions significantly lower than 100g/km.

The die-cast aluminum cylinder block is designed to reduce radiated and structure-borne engine noise, as well as cut weight. The high-pressure fuel rail and injectors are isolated from the cylinder head to minimize the transmission of pulsing, while the fuel pump and fuel line are acoustically treated.

An expected component for a modern triple is the use of a balancer shaft in the oil sump. For the 1.0-L SIDI Turbo, the shaft is driven by a chain with inverted teeth for quieter running. It spins at crankshaft speed and is mass-optimized to offset inherent three-cylinder vibrations.

The list of GME's items necessary for quieter, smoother operation include

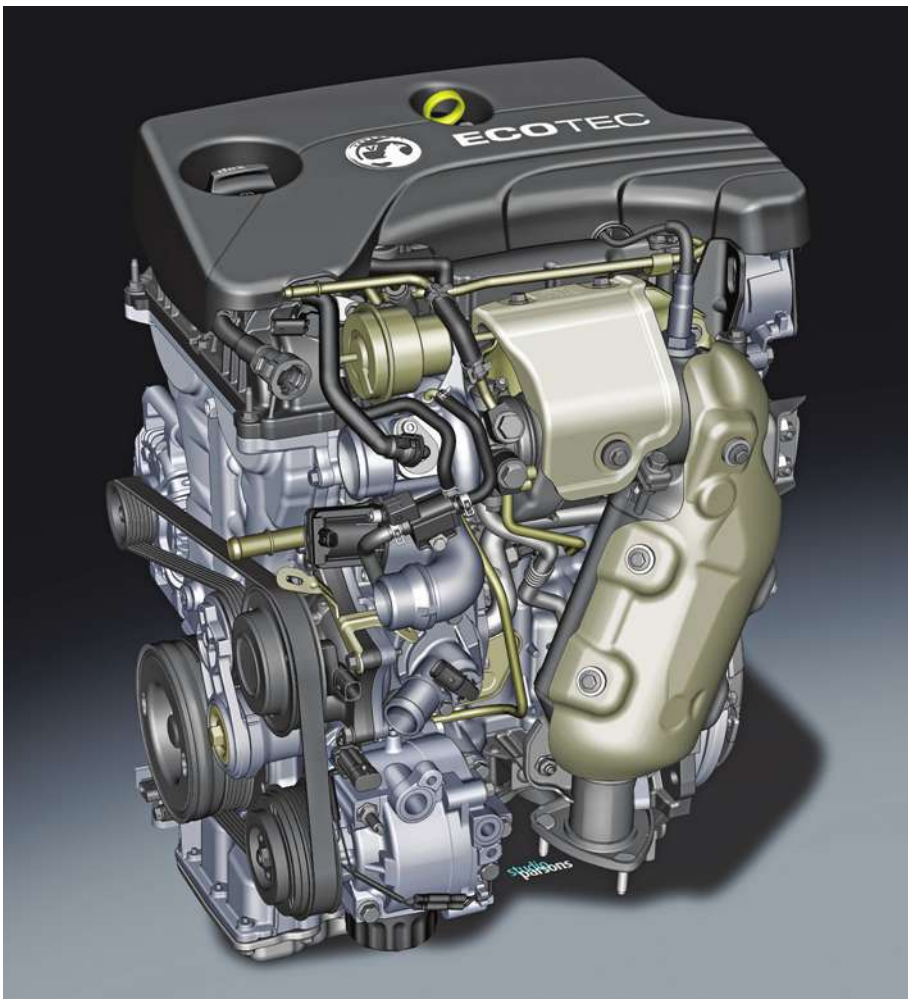

The new modular 1.0-L turbocharged DI three-cylinder engine is rated at 84 kW and 166 N-m.

General Motors Europe is the latest company to be cited in that definition. At the 2013 Frankfurt International Motor Show (Sept. 10-22), GME unveiled its 1.0-L, three-cylinder turbocharged gasoline engine. Known as SGE (Small Gasoline Engine), the direct-injected unit will be used to power the 2014 **Opel/Vauxhall** Adam city car, among other applications. It's a modular design which, in 1.0-L form, will deliver 84.6 kW (113.4 hp) and 166

on a line shared with diesel production, the 1.0-L is the initial member of a modular family of three- and four-cylinder units ranging up to 1.6 L, a portfolio that mirrors **Ford's** EcoBoost family.

Although the engine is new for GME, the concept is not. In 1996, the Opel Corsa was offered with a 1.0-L gasoline triple rated at just 40 kW (53.6 hp) and 82 N-m (60.5 hp). This *AEI* editor can attest that it was memorably breathless



TECHNOLOGY Report

acoustically optimized covers for the top and front of the engine, the intake manifold, and camshaft housings; crankshaft isolation with iron main bearing inserts; inverted teeth for camshaft drive chains; a low-hiss turbo compressor; and a lower oil pan in steel.

During bench testing at WOT, the new triple demonstrates lower noise levels across the rpm range than similarly powerful gasoline turbos up to 1.6 L, GME engineers claim. Because of this, the level of additional in-car sound insulation is significantly reduced, and complex engine mountings and subframes are not required.

All-new six-speed manual

Precision engineering is used in the integration of the exhaust manifold inside the aluminum cylinder head, which is bolted directly to the low-inertia, water-cooled turbocharger. The compact installation has been configured to help deliver a fast boost charge to optimize low-end torque. Maximum torque at 1800 rpm is almost 30% up on the 1.6-L Astra engine at the same rpm.



The new 1.0-L triple will drive through a new six-speed gearbox to achieve sub-100-g CO₂/100 km fuel consumption and emissions.



The 2014 Opel/Vauxhall Adam will be the first application for GME's new SGE triple.

Six-hole fuel injectors are centrally located above each piston, and dual cam phasing enables variable valve timing for required levels of engine breathing efficiency. Fuel consumption is further aided by use of a twin displacement oil pump and a switchable water pump. The latter is disengaged when the engine coolant is cold to facilitate faster warm-up.

The 1.0-L SIDI engine is allied to a new six-speed manual gearbox designed for medium torque applications. Its 37-kg (81.5-lb) dry weight is some 30% less than GM's incumbent six-speed, and its compact design is 375 mm (14.7 in) along its axis.

The transmission incorporates refinements recently introduced on GME's

next-generation gearboxes, including gears with wide, asymmetrically cut dog teeth and triple-cone synchronizers for first/second gear with double cones for third/fourth. Reverse gear is also synchronized.

The new gearbox will be used in a range of small and subcompact Opel and Vauxhall models with engines rated at up to 220 N·m (162 lb·ft). The matrix of gearing choices comprises 12 sets of gear ratios and seven final drives.

The 1.0-L SIDI Turbo and its new six-speed gearbox mark the latest step in a program for the renewal of GME's powertrain portfolio, which will include three new engine families and 13 new engines introduced between 2012 and 2016, plus several new transmissions.

That program began with the launch of the first engines in new midsize gasoline and diesel families. These 1.6-L turbo units will be joined by the 1.0-L SIDI Turbo, as the first example of a new, small-displacement engine family being built at Szentgotthard. There, gasoline and diesel engines are produced on a shared assembly line.

Stuart Birch



TECHNOLOGY Report

ENERGY

The case for alternative fuels

There would have to be compelling reasons to justify switching from petroleum for transport. Why? For one, as liquids, gasoline and diesel are easy to distribute. They are also energy-dense. A gasoline or diesel tank can be filled in a few minutes and carry the vehicle hundreds of miles more conveniently than any other fuel type.

Another stark fact stands out: the petroleum infrastructure is well established. There are 7000 oil rigs worldwide. There are 150 refineries in the U.S. alone, each processing between 5000 and 500,000 bbl per day. Worldwide there are more than 700 refineries pumping out about 80 to 85 million bbl per day of refined products, mostly gasoline and diesel. Oil refineries and rigs cost billions of dollars, representing a vast sunken cost. There is understandable inertia to keep producing and using gasoline and diesel.

One good reason to switch would be if we were running out of petroleum. At least for the near future, that seems unlikely as proved oil reserves continue to grow. Oil industry professionals continue to innovate, finding ways to extract oil profitably from miles under the sea floor or coax it from once recalcitrant tight and heavy oil formations with enhanced oil-recovery techniques such as hydraulic fracturing.

So, is there any reason to expect a rise in alternative fuels? Natural gas is growing in North America, especially in commercial vehicles, largely driven by the price difference compared to gasoline. Big automotive companies continue to invest in electric and hydrogen fuel cell vehicles. They must have their reasons.

Here are a few likely scenarios that might drive adoption before 2035.

Demand outstrips supply

The **International Energy Administration** (IEA) in 2012 projected worldwide demand for petroleum rising to almost 100 million bbl per day by 2035, from its current level of about 85 million bbl per day. The agency also predicted a doubling in worldwide growth in passenger cars to 1.7 billion. Countries such as China, Brazil, and India could rapidly

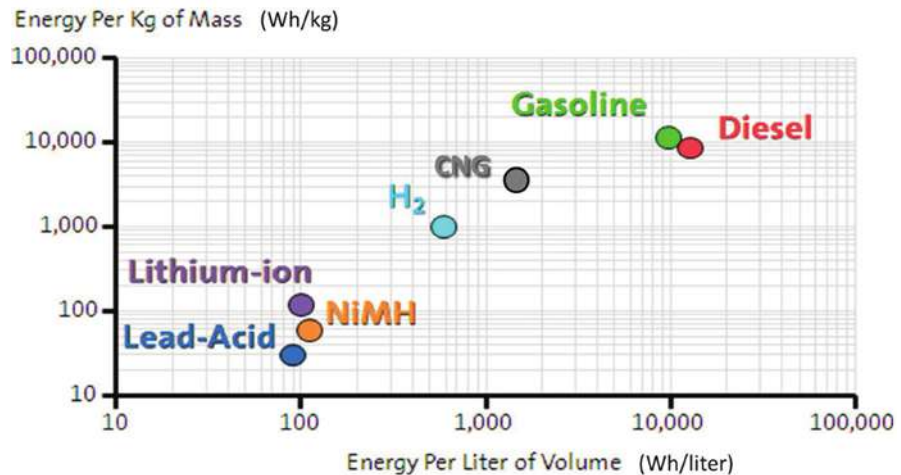

At present, storing electrons on board vehicles is less practical and consumes more space and weight than either gasoline, diesel, hydrogen, or compressed natural gas. (General Motors)

increase their car fleets beyond the IEA projections. If the oil industry could not invest rapidly enough, the resulting high gasoline prices might impel a switch to alternatives, although this might be economical only for a short time.

Urbanization and local air quality

Controlling pollution on a local basis within congested cities may spur local uses of alternative energies. Many countries are researching low emission zones (LEZ), where polluting vehicles are restricted. As an example, London's LEZ primarily targets diesel vehicles with gross vehicle weight (GVW) over 7000 lb. Besides outfitting either cleaner engines or filters, the London authorities also encourage a change to alternative fuels such as natural gas (though biodiesel does not meet the cleanliness standard). LEZs seem like a natural fit for either electric or hydrogen fuel cell vehicles.

Massive disruptions in the oil market

The oil market of 2013 is a global affair, with oil shipped far and wide to refineries that re-export refined products. There are a few choke-points in this distribution system. Supply problems could arise from earthquakes, hurricanes, wars, or civil disturbances in key critical areas. If this happens, the price of gasoline and diesel could rise to the point where alternatives become economical.

In some ways, the anxiety over supply is seen in countries that import more oil than others. The European Union coun-

tries, Japan, India, and South Korea all import 70-90% of their oil. Not surprisingly, some of them are investing in a number of alternative-fuels programs. India is the world's fifth and Italy is the world's sixth largest users of natural gas for transport. In 2012, 11% of Italy's new cars were natural-gas-powered vehicles. If supply anxieties were to bleed into other countries, expect alternative fuels programs to increase.

Technological breakthrough in electric batteries

On an energy basis, in many areas of the world, driving on electrons is cheaper than driving on oil. One estimate by **General Motors** in 2008 showed that at 10 cents/kW·h, it would cost a **Chevrolet Volt** owner only about 2 cent/mi, compared to about 12 cent/mi for gasoline at its price in 2008. While improving fuel efficiency will certainly change that ratio, the fact remains that electricity is usually cheaper. Building the initial infrastructure to deliver that electricity is also relatively cheap, easing the transition to electron mobility. If batteries could hold more, cost less, and charge faster . . . who knows? The economics of the fuel itself is compelling.

(The facts, graph, and conclusions for this article were drawn from the new **SAE International** book, "Future Automotive Fuels and Energy Technology Profile" by Bruce Morey, published in August 2013, ISBN 978-0-7680-7502-1, SAE Order Number T-128, <http://books.sae.org/t-128>.)

Bruce Morey

It's not just about 700,000 Ashok Leyland vehicles driving economies forward.

It's about touching the lives of
over 70 million people every single day.



Have you ever wondered how your monthly groceries get to your neighbourhood grocery store? Most likely on an Ashok Leyland vehicle. Your child probably gets to school on an Ashok Leyland bus. Nearly 70,000 of our logistics vehicles help the Indian Army keep our borders safe. It's not about manufacturing trucks and buses. It's about helping people move to better lives. And that's what we've been doing for over six decades - touching the lives of millions, including yours, around the world.



www.ashokleyland.com

TRUCK POWERTRAIN

Energy recovery choices for commercial vehicles

The rapidly growing importance of energy efficiency in almost all engine markets has presented a variety of opportunities to develop technologies to recover waste energy from engines and vehicles—including waste heat recovery (WHR), reduced engine idling (start-stop technologies), and kinetic energy recovery from vehicle braking. Selecting the right technology is heavily influenced by the vehicle type, use, and duty cycles.

There is also a gear set to match the power turbine speed to crankshaft speed. The engine fuel consumption improvement potential is 1.5 to 2.5% for typical line-haul applications. This estimate is in line with other studies.

Another variation is electric turbo-compounding where the power turbine drives an electrical generator. The electricity is used to power an electrical motor supplementing the engine output,

from the exhaust gas and exhaust gas recirculation (EGR) streams. The Rankine cycle describes a set of thermodynamic processes that extract waste heat from the engine and produce usable power—thereby reducing engine fuel consumption. Some systems can also seek to recover energy from the charge air cooler (CAC). The system includes a feed pump (FP) to drive the working fluid from the condenser to the three heat exchangers:

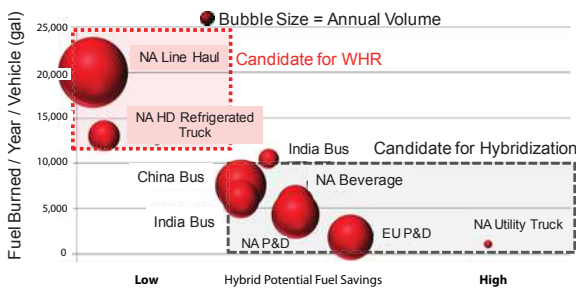

Evaluation of commercial vehicle applications for waste energy recovery potential. Waste heat recovery (WHR) is well suited for high-mileage vehicles with heavy payloads.

For vehicles with high mileage and large payloads, such as line-haul and heavy-duty refrigerated trucks, WHR is the better choice for energy recovery. In applications where the engine load factor is lower, and the drive cycle consists of a large number stop and go events; hybrid powertrains are better suited. Some applications, such as large transit buses, are a bit ambiguous.

For engines with high load factors, WHR is a good match for fuel efficiency improvement. The benefit of WHR is highest at full load and diminishes at light load. It is important to factor in the additional weight of WHR systems when determining vehicle-level fuel efficiency and freight efficiency impacts.

Two types of WHR of particular interest include turbocompounding and Rankine cycle. Both require the use of an additional expander in the exhaust stream to extract energy from the exhaust. For mechanical turbocompounding, the power turbine is connected to the crankshaft to supply the additional power. This is typically accomplished via a fluid coupling to allow for speed variation and to protect the power turbine from engine torsional vibration.

Schematic of the Cummins organic Rankine cycle WHR system.

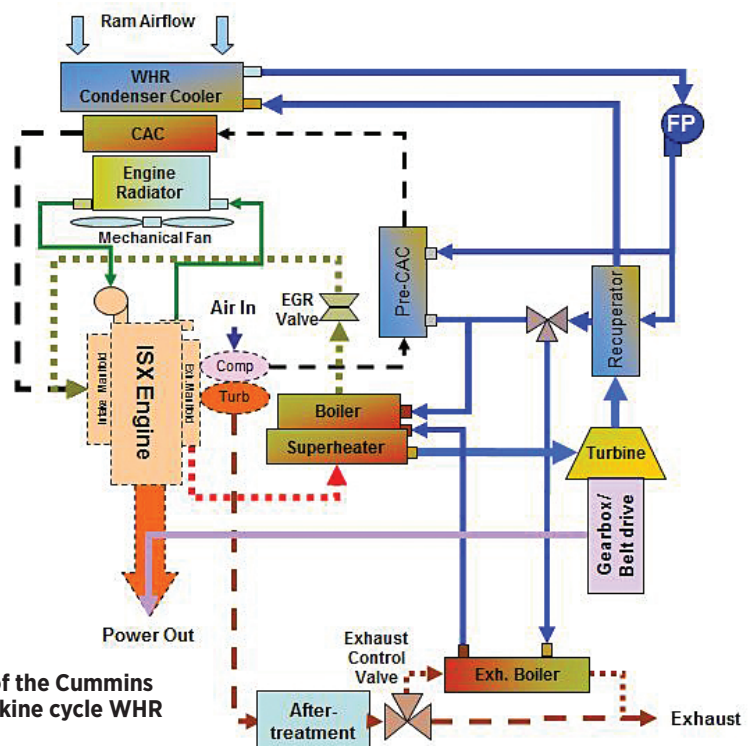

to charge batteries in a hybrid system, or to power electrified accessories. Considering the combined impact of supplemental power for the engine and electrified accessories, a 3 to 4% improvement in fuel efficiency can be obtained for line-haul applications.

Electric turbocompounding has significant implications for the vehicle architecture if the full engine fuel efficiency impact is to be realized. This includes the electrification of vehicle accessories, the addition of an electric motor to supplement engine output, and an energy storage system to accumulate any energy from the power turbine that is not immediately used.

A Rankine cycle is another WHR option to extract useful work from the waste heat of the engine—most notably

- Super heater-boiler—transfers waste heat energy from the engine EGR stream to the working fluid.
- Exhaust boiler—transfers waste heat energy from the exhaust gas stream to the working fluid. This is done downstream of the aftertreatment.
- Pre-CAC heat exchanger—transfer waste heat energy from the CAC to the working fluid.

A turbine expander takes energy from the working fluid to make mechanical power. The working fluid then passes through the condenser that rejects unused heat energy from the working fluid before starting a new cycle. The power generated by the turbine expander is coupled to the engine output shaft by a gearbox. Alternative architectures can be used to make electricity, which in turn can



TECHNOLOGY Report



Installation of the WHR system in a Class 8 tractor.

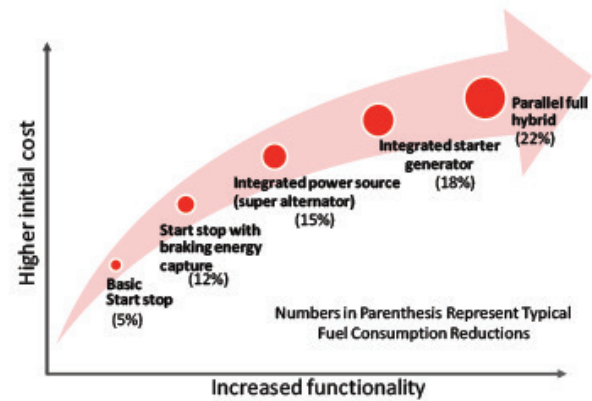

Hybridization technology roadmap with fuel efficiency improvement potentials. It is anticipated that the adoption of hybrid technologies will closely progress along the path shown, since initial cost remains a strong barrier.

power an electric motor supplementing the engine output, power electrified accessories, or charge a hybrid system battery.

The **Cummins** WHR system has been installed in a fleet of Class 8 trucks. Extensive effort results in a system with components that are packaged well with sufficient underhood airflow. Control systems provide robust management of the quality of the working fluid as it transitions through the components.

- Highway drive cycle (70% highway operation)—5.1 to 6.0%
- Regional haul (mix of highway and inter-city)—4.3 to 4.7%
- Inter-city (heavy transit bus and pickup/delivery)—2.5 to 3.7%

Vocational applications have a high proportion of stop-and-go operation and are ideal applications for hybrid powertrains, which recover waste energy from braking and idling and allow greater freedom for engine optimization. The U.S. GHG rule allows for the certification testing of hybrid engines and powertrains as a complete unit—the so-called ‘Power Pack Option.’

A variety of powertrain hybridizations are available, ranging from basic start-stop to parallel full hybrid. Like all waste energy recovery technologies, fuel efficiency improvement potentials are heavily dependent on duty cycle as well as the size and type of component technologies and vehicle control strategy. As more hybrid technologies are deployed, the potential fuel efficiency improvement increases for amenable drive cycles.

The basic start-stop functionality for commercial vehicles shuts down the engine when the vehicle stops. The engine restarts when the clutch is engaged for manual transmissions or restarts when the brake is released for automated manual transmissions (AMT). Additional challenges exist with auxiliary power requirements for line-haul applications and service trucks (power take-off) where sufficient electrical storage devices are required while the engine is not running.

Hybrid powertrains provide specific

opportunities for engine optimization that include:

- Reduced engine operating range with supplemental power from the motor—allowing the engine to operate in the region of highest efficiency
- Simplified aftertreatment due to reduced engine-out emissions through smoothing of transients and idle elimination
- Accessory electrification that allows parasitic loads to be reduced as the devices are operated on an as-needed basis
- Downsizing the engine may be possible in certain applications to meet average load compared to peak load—cost and weight reductions needed to partially offset the addition of hybrid components
- Downsizing is facilitated as available hybrid boost can mitigate increased shifting frequency at highway cruising speed, improving driveability and durability.

The challenges associated with waste energy recovery systems include:

- Increased vehicle cost and weight due to the additional components and complexity of the power management electronics for electrified vehicles
- Overall vehicle reliability due to the increased complexity
- Potential to not fully realize fuel efficiency improvements due to the high dependence on drive cycle, powertrain technology selection, and vehicle control strategy.

This article is based on SAE International technical paper 2013-01-2421 by Donald Stanton, Cummins, and was presented during the 58th Annual L. Ray Buckendale lecture at the SAE 2013 Commercial Vehicle Engineering Congress.

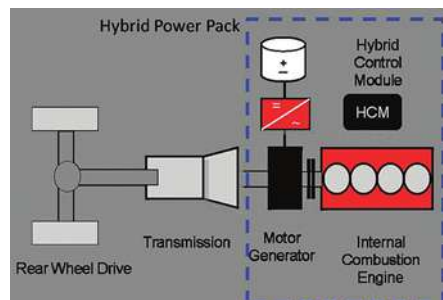

Pre-transmission hybrid electric drivetrain, showing the “power pack” components that are tested in the power pack certification option.

Extensive vehicle testing of the WHR system over a wide range of drive cycles (highway, regional haul, and inter-city) and ambient conditions indicates limited WHR from the CAC. Incremental fuel consumption reduction is achieved but may not support the added cost. The primary sources of economically viable energy recovery come from the EGR and exhaust streams.

Various levels of fuel consumption reduction are achieved as listed by drive cycle. The ranges represent data for a variety of ambient temperatures.



TECHNOLOGY Report

OFF-HIGHWAY ENERGY

Customers get fast payback from extra cost of Cat hybrid excavator

About 60% of the energy an excavator expends in an operation goes to swinging the heavy upper frame (or “house”) into position and then returning to the home position, according to **Caterpillar’s** Ken Gray, Global Project Manager, Large Hydraulic Excavators. A portion of that energy takes the form of heat, some of which is generated in braking the upper frame’s rotation when it reaches the desired position. In regular machines, the heat energy is shed to the atmosphere . . . Doesn’t do any good there.

Aleksandar Egelja, Ph.D., Engineering Manager, Advanced Hydraulic Systems, Caterpillar, declined to reveal precisely how efficient the 336E H hybrid system is, telling *SAE Off-Highway Engineering* magazine only that “we believe our system to be very efficient in the ability to capture almost all of the available swing kinetic energy.” There are small losses owing to factors including “pressure drop, internal oil leakage, thermodynamics, etc.”

“Our system is designed to allow accumulator charge up to 32 MPa, which

is right in line with our swing system operating pressure,” Egelja added.

Users will see significant savings from the hybrid technology, according to Caterpillar. There is a price premium for the 336E H, which is a hybrid variant of the base 336E, because of the hybrid development effort and associated hardware on the machine. The premium will vary from dealer to dealer, Gray said, but on average he expects it to be 9%.

Customers can recoup the premium in as little as a year in heavy-use applications, he said. A more typical payback period will be about 18 months. The more often the machine is used, the faster the payback, Gray noted. For some companies, the payback period might run out to 24 months.

“If it’s longer than 24 months,” Gray said at an April 4 media briefing on the 336E H near Cat’s headquarters in Peoria, IL, “I would question that maybe you need a smaller machine . . . Or it might be a situation where you’re not getting enough work.”

Hybridization constitutes one of the 336E H’s three main “technology themes” or “technology building blocks.” They are the three main ways in which the 336E H is different than the base 336E.

Hybridization falls into the “reuse” technology theme.



Caterpillar’s 336E H excavator is the “generation one” hybrid machine that will be followed by others, the company says.

Caterpillar has come up with a way to capture that energy, store it, and reuse it later. The system is designed such that the upper frame hydraulic braking action forces the fluid into two long cylindrical accumulators. The accumulators contain nitrogen gas, which is compressed as they are filled with fluid. The nitrogen-filled ends of the piston-type accumulators can be thought of as loaded springs when pressurized by the incoming fluid. A valve closes to keep the accumulators under pressure immediately after the upper frame has come to a stop. The valve is opened and hydraulic fluid flow reverses course when the excavator operator commands upper frame movement, powering the hydraulic swing motor to rotate the house.

Internal Validation Testing ^a : Comparison of 336E H, 336E (base machine), and 336D (previous-generation machine)			
	336D	336E	336E H
Productivity ¹	Baseline	+7%	+11%*
Fuel consumption ²	Baseline	-7%	-34%*
Fuel efficiency ³	Baseline	+15%	+68%*

^a=90° bench truck loading application

¹=Amount of material moved/unit of time

²=Amount of fuel used/unit of time

³=Amount of material moved/unit of fuel

*=Compared to baseline

Internal Validation Testing: Fuel Consumption (Gal/h) Comparison, Common Applications			
	336D	336E	336E H
Bench truck loading	Baseline	-7%	-34%*
180° truck loading	Baseline	-8%	-30%*
90° truck loading	Baseline	-9%	-29%*
Trenching	Baseline	-4%	-28%*

*=Compared to baseline

1. Conserve Fuel

Electronic Standardized Programmable (ESP) Pump

- Reduced engine speed for fuel savings and quieter operation
- Higher pump displacement with greater efficiency
- Ensures smooth transition between power sources
- Maximizes efficiency and productivity by matching engine/pump load



The “conserve” technology building block relates to a new electrohydraulic pump that provides flow only when, and only where, it’s needed.

The others are “conserve” and “optimize.” In addressing the “conserve” theme in his April 4 media presentation, Gray characterized the traditional approach to excavator design: “We’re going to run this machine at a certain speed and we’re going to drop an engine into it that will run the machine at that speed.” For the 336E H, the opposite approach was taken. “The “conserve” element of this program,” he explained, “is running the engine at its optimum speed, and making adjustments to the rest of the machine to accommodate that engine running at its optimum fuel consumption point.”

And so engineers kept the C9 engine that’s in the base 336E and slowed it from 1800 rpm to a maximum 1500 rpm on the hybrid. “And we’ve put in a larger-displacement electronically controlled pump so we get the same hydraulic power output and a lot faster response with electronics controls, but we’re running the engine at its sweet spot—at its lowest fuel-consumption rpm,” said Gray.

Product Application Specialist Brian Stellbrink in a later presentation noted that operators enjoy a quieter cab because the engine runs at lower rpm. Otherwise, they experience 336E H as they do the 336E, including the same cycle time.

Using an electrohydraulic pump with intelligence rather than a hydromechanical one, Stellbrink continued, “enables us to control it more efficiently to provide flow when it’s needed, but, more importantly, only when it’s needed. That’s a key difference.”

He added that engineering efforts to add electronic controls to the pump “have been in development for some time, and we’re applying them now on the hybrid.”

The “optimize” element of the design is the adaptive control system (ACS), which is a new metering valve that works faster and allows independent control of functions “that before worked as one,” said Stellbrink.

“Nothing moves on an excavator without hydraulics,” he explained. “If you think of why the engine’s in that machine, it’s there to turn those pumps. That’s it. So this valve is really the traffic controller, the flow controller. It’s the brains behind the system that tells that oil where to go: bucket, stick, boom, swing, tracks.”

2. Optimize Performance

Adaptive Control System (ACS) Valve

- “Brain” of system “Traffic control”
- Algorithms independently control machine functions
- Reduces fuel consumption by reducing pressure losses
- Hydraulic regeneration
- Energy where you need it, precisely when you need it



The “optimize” technology building block relates to a new metering valve that allows independent control of functions.

3. Reuse Energy

Hydraulic Hybrid Swing System

- Recovers/reuses otherwise wasted swing braking energy
- Less load on engine results in fuel savings
- Non-flammable pre-charged nitrogen gas accumulator
- Fully serviceable



The “reuse” technology building block relates to twin accumulators that store energy in the form of hydraulic fluid under pressure.

The conserve and optimize elements of the engineering design deliver efficiency benefits in all machine-use scenarios. They contrast with the re-use (hybrid) element, which is of benefit only when the upper frame is rotating. Gray doesn’t think that is much of a disadvantage given how a typical excavator is used: “It’s not on a job site if it isn’t swinging.”

Cat has filed for more than 300 patents for the 336E H. Gray declined to divulge Caterpillar’s full hybrid strategy for excavators, but did say there will be two additional models: 336F H and 336D H. He noted that the company had considered electric hybrid technology for the 336E but in the end opted for hydraulic technology. Electric hybrid technology will be considered for future products, Gray added.

A video of the 336E H produced by *SAE Off-Highway Engineering* can be viewed at <http://video.sae.org/11698>.

Patrick Ponticel

TECHNOLOGY Report

AEROSPACE PROPULSION | MATERIALS

Testing new materials and technology for the aerospace industry



Ask any engineer about the single greatest challenge the aerospace industry faces over the coming 20 years, and they will say fuel efficiency.

With oil reserves being consumed at an unprecedented pace as global demand rises and prices continue on a consistently upward trend, short of a new power source being invented, fuel will remain as the single largest operating cost in aviation.

To deliver a more efficient aircraft, engineers typically focus on three key areas: improving aerodynamic profile and wing structure, mass reduction, and an engine design that can deliver increased fuel efficiency.

However, aerodynamic efficiency and mass reduction are areas necessarily constrained by the current limits of technical engineering ability and material properties. Put simply, there is little potential for drastic improvements in these areas in the near future when taking into account current capabilities.

In recent years, the simplest route to achieving improved fuel efficiency has traditionally come from a combination of low drag coefficient profiles and engines that burn fuel at a higher temperature to maximize economy. But the industry has hit something of a wall; the scope for simply raising fuel-burning temperatures or cooling engines is now relatively limited, with the hybrid metal-based

alloys currently deployed in fixed-cycle engines operating at the upper limits of their temperature threshold of 2200°F. For both commercial and military jets, the current generation of engine designs has ceased to deliver impressive results, with any improvements being incremental in nature.

The problem facing the industry is how to continue to offer improvements in engine operation when designs are already working to their limits.

Engineering solutions

To design engines capable of exceeding these limits, there are two approaches currently being explored by the heavily staffed R&D departments of the global aerospace engine manufacturers. The first depends on further cooling the air inside the engine, which demands an entirely new, revolutionary engine architecture.

Today's fixed-cycle variants will eventually be replaced by variable cycle designs, which use sophisticated airflow control systems to create regulated temperature pockets and are predicted to deliver improved efficiencies across the entire flight envelope.

The second approach is to develop new materials for use within engines—ones able to withstand temperatures exceeding the current limit of metal alloys. The most viable new materials for this are ceramic matrix composites (CMCs), which promise to deliver unprecedented resistance to temperatures far exceeding current levels.

Indeed, CMCs are already being introduced and have been utilized within the **CFM LEAP** high-bypass turbofan engine, currently being developed in a joint venture between **GE** and **Snecma**. The preliminary statistics are highly encouraging, with anticipated increased efficiency that will see fuel consumption reduced by 16%.

But this is only the leading edge, and the full extent of the advantages CMCs will offer is yet to be explored. As with the early stages of any material development with potential application in the aerospace industry, rigorous testing is required.



Almost every design choice or innovation for the next generation of aircraft is being made with increased efficiency as a goal.

Testing times and conditions

When testing a new generation of materials to gather robust data, unforeseen challenges always arise and a new methodology is sometimes required. This has certainly been the case in the early stages of CMC development, and its unique resistance to sustained, intense heat brought up several interesting complications.

DRIVE HOME THE CHEETAH-INSPIRED XUV500 TODAY.



INTERFACE 380007

The country's most* awarded SUV awaits you in our showroom. So if you want to experience the XUV500's cheetah-inspired styling, power-packed performance, refined craftsmanship, advanced technology and best in class safety, visit your nearest Mahindra dealership today.

- mHawk¹⁴⁰ engine with 6-speed transmission • All Wheel Drive (AWD) • Electronic Stability Program (ESP) • 6 Airbags (front, side, curtain) • ABS with Electronic Brakeforce Distribution (EBD)
- 6" Touchscreen infotainment with GPS • Fully Automatic Temperature Control with dual HVAC • Leather upholstery • Voice Commands • Tyre-tronics • Hill Hold & Descent Control
- Static-bending projector headlamps with LED parking lights • Micro Hybrid Technology • Cruise & Audio Controls • Smart rain & light sensors • Intellipark reverse assist



MAY YOUR LIFE BE FULL OF STORIES

To experience it, SMS 'XUV500' to 575757. For more information call us at 1800-266-7000. Vehicle body colour and features may differ from printed photographs. Accessories shown may not be part of standard equipment. Please check model details with your nearest Mahindra dealer. *In India in FY. 2011-12.



youtube.com/mahindraxuv500



facebook.com/mahindraxuv500



twitter.com/mahindraxuv500 www.mahindraxuv500.com

TECHNOLOGY

Report

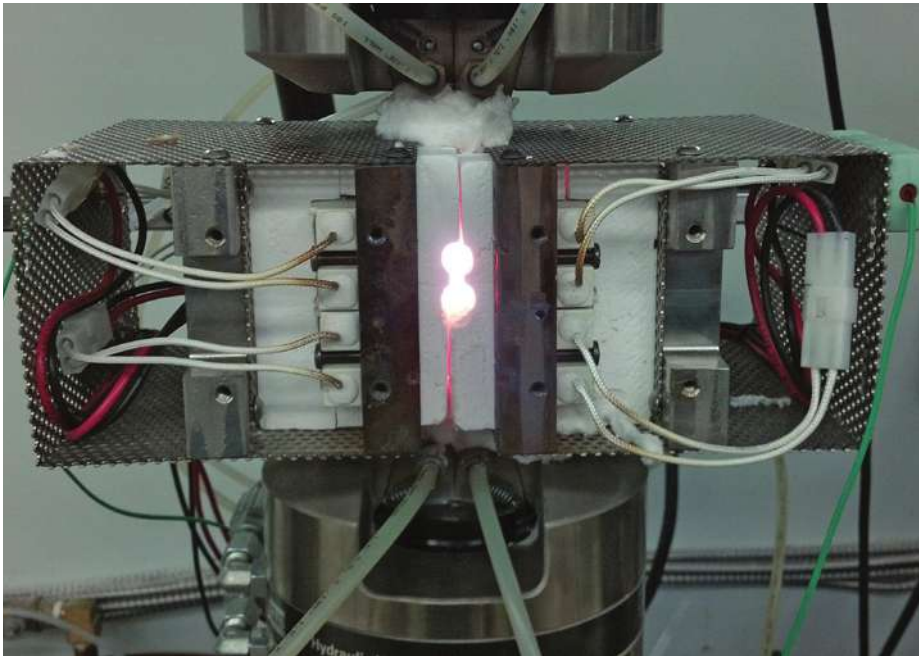

To be able to test a new generation of CMCs, Element Materials Technology designed and built a furnace using a machinable monolithic ceramic block, which was fashioned into a chamber before being exposed to heat and hardened into shape.

The first major obstacle was equipment; put simply, when looking to test material at 2700°F and beyond, there was no commercially available furnace that could reach, let alone maintain, the required temperature levels. **Element Materials Technology** designed and built a furnace from the ground up using a machinable monolithic ceramic block, which was fashioned into a chamber, before being exposed to heat and hardened into shape.

Then there were other seemingly minor but still critical obstacles the testing team had to overcome, such as how to hold a sample in place in the new furnace when every existing technique could not withstand the pressure and heat required throughout the testing process. A tool for holding samples in place in the new furnace had to be designed and fabricated from scratch.

The single biggest challenge encountered, though, was when attempting to measure the temperature of the sample. Gauges that operate by making physical contact with samples were unsuitable, as the equipment typically used ignited a reaction at higher temperatures, causing a test failure. The standard alternative has been to use thermocouple probes, which can detect sample temperatures with precision from a microscopic dis-

tance, so that no contact is made. But this proved ineffective in delivering the data needed at these unprecedented temperature levels.

Element again had to turn to brand new methods to surmount this problem, devising a treated liquid ceramic coating to create a new generation of probes. These could touch the sample without a reaction, ensuring a complete set of test results at temperatures up to 2700°F and even delivering a higher fidelity of test results at lower temperatures than those obtained using contemporary techniques. But this method, as with any, has its limits. With CMCs expected to be able to effectively withstand temperatures in excess of 3000°F, Element is already exploring future techniques to enable testing in even more extreme conditions.

Despite having successfully designed, built, and tested the necessary equipment, challenges continued to arise even before the actual materials testing. Primarily, there was the question of what size and shape samples would best enable testing of the heat and corrosion resistance, mechanical properties, strength tension, compression, and durability of CMCs. The materials themselves are also tremendously expensive—currently around five times the cost of metals.

The industry is still in the early stages of understanding CMCs. However, thanks to the unique nature of the material and the evolving research and methodology required to test it, such challenges are only the beginning. There is a high degree of confidence that any obstacles can and will be overcome and that CMCs are already worth the significant investment. The impressive results released from the LEAP high-bypass turbofan engine test, which depended in part on the CMCs used in its construction, are just a preliminary indication of what this technology can achieve for the aviation industry.

Propelled forward: the future

If aerodynamic efficiency and mass reduction cannot be relied on to deliver the efficiencies required, then the Holy Grail for developers is an engine that combines the increased burning temperature of engines using CMCs with the cooling properties delivered by the adaptive airflow systems of variable-cycle designs.

A viable engine is still a few years away from development, but initial research into such propulsion systems is under way. GE recently announced dramatic results from its engine core test with the **U.S. Air Force Research Laboratory's** Adaptive Versatile Engine Technology program. The new engine core achieved a 25% improvement in fuel efficiency, a 30% increase in operating range, and a 5-10% improvement in thrust compared to today's fixed-cycle engines. The combination of CMCs with an adaptive low-pressure spool allowed the engine to generate the highest combination of compressor and turbine temperatures in aviation history, ensuring fuel was burned with far greater efficiency than ever before.

As the aerospace industry becomes more familiar with CMCs and continues to develop test methodology, these figures will no doubt be surpassed. Once manufacturing techniques have been perfected and the material becomes ubiquitous, economies of scale will ensure that costs are reduced, paving the way for faster, cheaper innovation.

David Podrug, Advanced Materials Business Manager, Element Materials Technology, wrote this article for SAE's *Aerospace Engineering* magazine.



AUTOMOTIVE ELECTRONICS

Why VW is anticipating trouble ahead



“Seeing” around the corner: VW’s Car2X communication system promises significant support for driver safety when approaching road work.

“Driver assistance” is a phrase that can send a shudder of concern through the administrative and financial hierarchy of the motor industry as technologists come up with yet another solution to a problem that may be difficult to discern. It can create added complexity and cost, and the end user can become thoroughly discombobulated by a multitude of system choices and functions that may effectively increase workload and require too much attention, thus defeating its *raison d’être*.

All this is very much on the minds of engineers and designers at Volkswagen’s Wolfsburg R&D center while considering the words of VW Group Chairman Prof. Dr. Martin Winterkorn: “Volkswagen is the large-scale brand that stands for innovation and engineering prowess.”

Many new driver-assistance technologies are primarily concerned with safety and ease of use, but they need to be carefully developed and applied to give easy-to-understand alerts and also to maximize use of existing components, sensor and system bundling, and efficient packaging. Relevant sensors and supporting systems for safety and driver support include ultrasonics, radar, cameras, and Wi-Fi, all under the umbrella heading of communications: car to car, transport infrastructure to car/driver, vehicle to driver.

Driver friendliness is a must, and *AEI* experienced several of VW’s development programs to inform, warn, and support drivers facing potential hazards.

VW is bundling emergency assist, advanced lane assist, and partial vehicle piloting systems to help control the outcome of a medical emergency or the effect of driver fatigue.

“It is about keeping the vehicle of an unconscious, sleepy, or inattentive driver in a lane and stopping the vehicle safely,” explained Development Engineer Bastian Schmidt. “It involves a warning to the driver, slowing the vehicle to a stop if necessary, and operating the hazard warning flashers, the whole process—depending on speed—taking about 10 to 20 s.”

The process is initiated by a total lack of steering inputs over a specified period or if the driver’s hands are not on the steering wheel. Lane assist keeps the car within the bounds of the lane in which it has been traveling provided there are lane markings. The hazard lights are initiated and radar-based adaptive cruise control is engaged to prevent a collision with any vehicle/object ahead.

An initial quiet acoustic warning is given (the theory is not to startle the driver), followed by a louder sound if necessary (this *AEI* editor felt the louder sound should be applied at the start of the perceived emergency), and the brakes are applied briefly but sufficiently hard to awaken a sleepy/sleeping driver. If there is still no driver input with hands on the steering wheel, the vehicle is brought to a standstill.

VW believes it will be first to market such a system.



VW boss Prof. Dr. Martin Winterkorn is pushing his engineering teams to achieve innovation and engineering prowess in the area of driver-assistance systems.

Car2X communication is a particular area within which applications are set to burgeon. One concerns road work (construction).

Volkswagen’s Car2X Safety involves the exchange of information between vehicles and transportation infrastructure with an automotive WLAN (wireless local area network) standard forming the foundation of the communication. In effect, said VW’s C2X Development Engineer, Florian Weinert, it is a system that can allow the driver to “see” around corners: “For example, if there is a construction site on the road ahead, but out of an approaching driver’s vision, his or her car can receive a warning message.”



TECHNOLOGY

Report

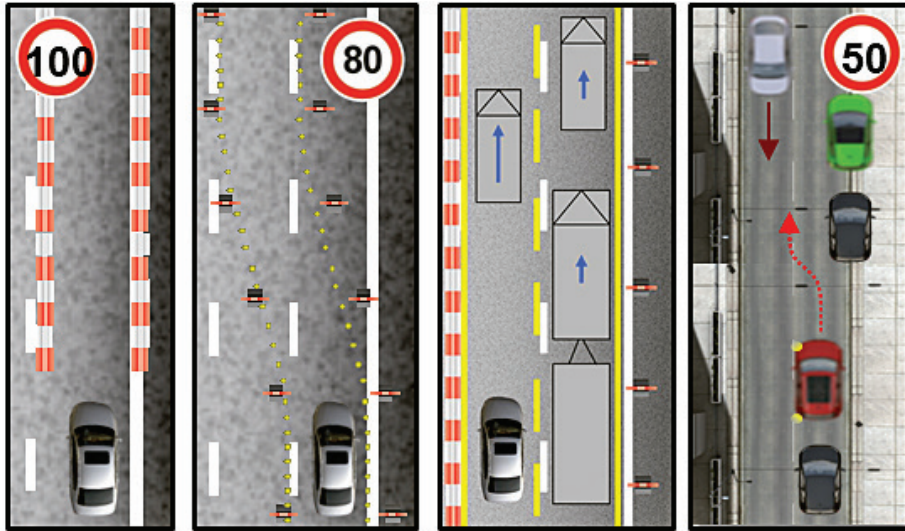

Electronic support for safer negotiation of road work is a major part of VW's current development work.

VW is backing a camera-based trailer reversing system as part of its driver-assistance program.



This is transmitted by a car ahead or via a portable piece of site infrastructure. It first involves an alerting caption in the driver's information display, followed by an audible warning and a countdown to the hazard in meters.

Consideration is being given to linking the system to a head-up display as an attention getter, possibly using an exclamation mark to take the driver's eyes to the instrument display, or to give a distance-to-hazard message.

The Car2X communication is regulated by the ITS G5 standard of the ETSI (**European Telecommunications Standards Institute**) and actions of the European **Car 2 Car Communication Consortium** (C2C-CC)—a non-profit, industry driven organization initiated by European vehicle manufacturers and supported by equipment suppliers, research organizations, and other partners. The C2C-CC is dedicated to further increasing road traffic safety and efficiency by means of cooperative Intelligent Transport Systems (C-ITS) with vehicle-

to-vehicle (V2V) communication supported by vehicle-to-infrastructure (V2I) communication.

Car2X Safety enables networked mobility over a distance of several hundred meters, with multiple exchanges of information occurring by the second, explained Weinert.

And when a car arrives safely at the road-work site, VW has further safety aids for the driver, using developments of established lane assist technology to incorporate the Roadworks Assist function to help guide the driver along narrow lanes marked by cones or temporary guard rails, particularly at night or in low-visibility conditions.

VW states that safety studies have shown that the greatest accident risk occurs when crossing the center line with a driving lane banking angle of 10%, lane width of 2.5 m (8 ft), and maximum legal speed of 80 km/h (50 mph) over a bend radius covering 300 m (980 ft).

To improve safety, the Construction Zone Assistant incorporates a stereo

camera with stereo image processing plus a mono camera to detect lane markings, supported by four ultrasonic sensors to measure distances to other vehicles (especially trucks and buses) in any adjacent lane or lanes.

The fusion of camera data and ultrasonic sensor data produces a modular surroundings model, allowing a computer to achieve a driving corridor analysis that predicts the car's direction, checks for possible collisions, and determines the desired direction of the driver's vehicle.

Adaptive cruise control and brake assistant also play roles for steering correction and automatic braking as deemed necessary.

At night, Visual Driver Aid in road work is also being developed. Using LEDs, it "paints" two light stripes onto the lane ahead of a car to aid driver assessment of lane width. A further development of this could project variable lines in front of the vehicle that would represent the desired driving lane and also show potential interventions by the Construction Zone Assistant.

Development challenges at present include overcoming the risk of dazzle caused by the LED patterns being projected onto a wet surface.

Other systems being developed at Wolfsburg include a camera-based high-definition 3-D bird's-eye view of the vehicle and its surrounding area, including cross-traffic, blind spot monitor and rear-traffic alert for reversing out of a parking spot with view shielded by other vehicles, and park assist for frontal approach to perpendicular parking spaces. Remote-controlled driver out-of-vehicle technology continues to be developed, as does a trailer hands-off-the-steering-wheel reversing system using cameras but requiring the driver to preselect the trailer angle.

An electromechanical brake booster (eBKV) to improve established automatic braking systems is also being developed by VW. Designated Fast Brake and incorporating current production components to save manufacturing costs, it can cut braking distance from 30 km/h (19 mph) by 1.3 m (4.3 ft). The system could help meet scheduled 2015 EuroNCAP and will be available in VW's pure-electric vehicles. It would also be suitable for hybrids, with further applications likely.

Stuart Birch

AEROSPACE AVIONICS

A touch of simplicity in the cockpit

Specialists who design human-machine interfaces are reducing pilots' cognitive workload with a concept used from early childhood. When they want to manipulate something, they reach out and touch it.



Pilots can adjust views by touching Garmin's interactive display panels.

Controlling a pricey aircraft miles above the Earth is definitely not child's play, but touch input sensors used with flat panel displays are making it simpler to manage flight activities. The combination of touch and liquid crystal displays is also reducing the area that pilots have to focus on. Screens can be programmed to make better use of limited cabin space, giving pilots different input during landings, takeoffs, and flight.

For example, **Garmin** expanded the capabilities of its GTN touch-screen line, adding support for weather radar, advanced ADS-B capabilities, and other tasks. The touch screen lets pilots adjust the tilt or sector scan by swiping their finger across the display.

They can also overlay the weather radar right on the moving map page, improving situational awareness. An additional benefit of using touch input is that the digital controls can evolve even after planes are in operation.

"The GTN series was designed with a growth-oriented architecture that allows

for new technologies and expanded capabilities to be accommodated via software updates," said Carl Wolf, Garmin's Vice President of Aviation Sales and Marketing.

Digital controls also give pilots the flexibility to alter controls to suit current needs. The new **Beechcraft** King Air employs **Rockwell Collins'** Pro Line Fusion touch screens on all flight displays. Pilots can alter the controls while gaining the focus that comes when controls and displays are in the same place.

"The incorporation of touch controls, along with traditional cursor controls, allows the crew to choose the best operation model for the task at hand, based on their preferences or the environmental conditions," said Dave Gribble, Principal Systems Engineer at Rockwell Collins. "The use of touch on the flight displays breaks the traditional control/display paradigm, where avionics func-

The Curtiss-Wright display also highlights a growing trend toward higher resolution and LED backlighting. It provides native resolution of 1920 x 1080 while utilizing dual LED backlighting. LEDs provide high readability in daylight while letting pilots switch to a filtered mode when night vision goggles are being worn.

While much of the interest in controls centers on the changes wrought by flat panel displays, established controls aren't totally disappearing.

"Conventional controls like knobs and buttons will always have a place in the cockpit. They are most effective where immediate or frequent access is required to a function at any time," Gribble said.

Many observers feel there is little interest in two control techniques gaining popularity in automotive and consumer electronics: voice, and gesturing.



Curtiss Wright has increased the size of its touch input display line.

tions are controlled in one place and displayed in another."

Touch sensitive displays are expanding in size as pilots look for even more features and functions, for both commercial and military applications.

In March, **Curtiss-Wright** Controls Defense Solutions unveiled a 21.5-in touch display aimed at military and law enforcement markets. The Skyquest can be customized with user-definable soft keys that let common tasks occur with a single keystroke.

Voice doesn't have the recognition rates or vocabulary to make it useful in noisy cockpits. One concern is that if pilots must say specific commands, thinking of the proper command will take more effort than using manual controls.

Gesturing may work for gaming and television controls, but pilots often move too much to make it useful. That's particularly true when planes are being buffeted, which often causes unintended arm movements.

Terry Costlow

TECHNOLOGY Report

AUTOMOTIVE INTERIORS

CGT's new coverstock exceeds 40% sustainable content

Canadian General-Tower's (CGT) new Vehreo coverstock uses recycled post-consumer waste and biological-based feedstocks as key ingredients in a material composition with an overall sustainable content that exceeds 40%.

"Vehreo's composition is a vinyl-coated fabric with bio-based and recycled content. The backing fabric is made with 100% recycled yarn, and the PVC film has a minimum 20% bio-based and recycled content," Margaret Soares, Product Development Specialist for CGT Ltd., told SAE Magazines.



Canadian General-Tower's sustainable synthetic coverstock, Vehreo, mimics the look and feel of leather.

CGT's commercially available coverstock uses Unifi Inc.'s Repreve-branded fabric as the supporting textile for the flexible skin. The Repreve fabric is 100% PET (polyethylene terephthalate) hybrid polyester. A bio-based formulation that includes soybean oil and castor bean oil serves as the flexible skin.

During the proprietary production process, approximately 1.5% of the edge trim's skin is recycled and accounts for approximately 4% of the coverstock's content by weight.

"The formulation in the skin and foam contribute to the sustainability of the material, while the textile contributes to the recycled content of the product,"

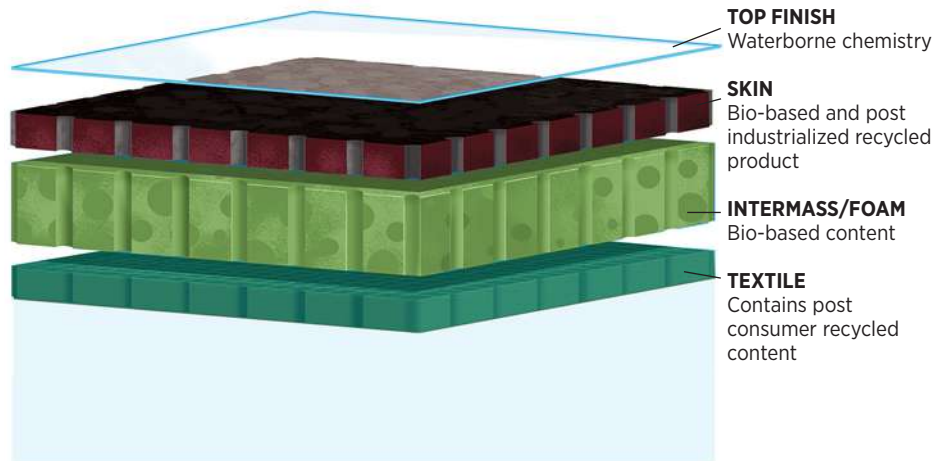

CGT's Vehreo synthetic material uses a textile backing made of recycled bottles (Repreve) and adds a biological-based intermass and skin with a waterborne top finish. The material allows for design flexibility and can be used on any interior trim part while maintaining its haptics and appearance.

according to Soares, a materials science engineer.

CGT's eco-smart surface has the look and feel of leather.

"Our product goes through the same rigorous testing as a conventional coverstock. There are no shortcuts to the testing. Vehreo meets sun, odor, fogging, and other OE requirements," said Soares.

Innovative engineering enables CGT material specialists to meet material breathability and other targets.

"We can add or subtract raw materials to the formulation. We can add micro-pores on the skin. We also can lessen the attraction of the sun—making the material cooler to the touch—with a specific surface treatment," Soares said.

Lilana Nicoghosian, Product Marketing/Design Manager of CGT's Automotive Products Division, said synthetic material usage is gaining in popularity.

"We're going to see more synthetic materials incorporated into the automotive interior. These materials have a very deceiving look. You actually can't tell what the material is when looking at it. And that's part of the attraction," Nicoghosian said.

Sustainable synthetics can be especially appealing to the millennial generation, representing persons born in the late 1970s through the early 2000s.

"The younger generation identifies with synthetics as an engineered material. They like the look and the technology behind it," Nicoghosian said. "The OEM design studios are really keen on that. They know that future buyers like that type of look, so providing the look within an eco-friendly technology is really the way to go with automotive interiors."

Initial production of Vehreo, which can be used for seats as well as door panels and other interior trim locations, will occur at CGT's production center in Cambridge, Ontario, Canada. The facility became the first manufacturing plant in North America registered to ISO 14001 environmental standard compliance in 2000.

Vehreo's vehicle application debut is likely in MY2017. "We're working with several automakers to position the product based on their sustainable strategy," Soares said.

Kami Buchholz

Smalley Wave Springs

All Springs Are Not Equal®

free samples • free CAD models



SAVE SPACE

- Reduce spring heights by up to 50% compared to coil springs
- Same force and deflection as coil springs
- Fits in tight radial and axial spaces

STAINLESS STEEL FROM STOCK

- 4,000 stock sizes in carbon and stainless steel
- Available from 6 mm to 400 mm diameters from stock
- No-Tooling-Costs™ on specials; available from 5 mm to 3000 mm

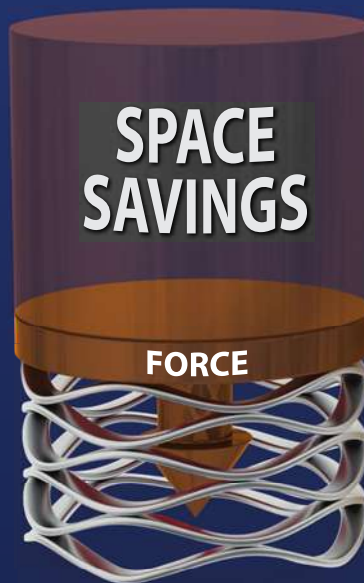

SMALLEY WAVE SPRING



COIL SPRING

www.smalley.com



www.smalley.com/getcatalog • info@smalley.com

Lake Zurich, IL • USA • +1.847.719.5900 • Fax: +1.847.719.5999

TECHNOLOGY

Report

AUTOMOTIVE BODY

Lightweight carbon-fiber and SMC body panels under development

Carbon-fiber composite car structures are in vogue this year. **General Motors'** Corvette Stingray sports a carbon-fiber roof and hood. Other recent autos that feature carbon-fiber-reinforced polymer (CFRP) components include the **Audi R8**, the **BMW M6**, and the **Dodge Viper**. Most of these models, however, are high-end, low-volume vehicles that are mainly assembled manually because use of composites in low- and medium-priced cars still awaits the development of cost-effective mass-production processes.

Wehmeyer, an advanced materials and processes research engineer at **Ford's** European Research Center in Aachen, Germany.

To make the most familiar type of CFRP parts, technicians typically lay-up net-shape prepregs—woven preforms of carbon fibers that are impregnated with thermoset epoxy resin—in clamshell-like molds. The workers then place the molds in autoclaves to cure them at high temperatures for an hour or two. But several ways to make composite parts are now under development, including various

Plastics (CSP) of Troy, MI, illustrate this trend.

Automakers' CFRP research

Ford, for example, unveiled last fall a version of its Focus compact with a carbon-fiber hood that weighs half that of its steel counterpart. A research collaboration with several partners fabricated the part using a high-speed manufacturing process that could be suitable for high-volume production, according to the automaker. To develop the technol-



Carbon-fiber-reinforced SMC hood inner structure adds strength to CSP's two-part composite hood prototype.



Low-density SMC outer panel of CSP's two-part prototype hood provides robust exterior with good surface appearance.

The engineering appeal is clear, though. CFRP composites can have about a fifth of the density but all the strength and stiffness of steel. They also provide engineers with greater design flexibility and the opportunity to cut parts counts. But the drawbacks of CFRPs—high costs and slow manufacturing throughput—are tough challenges: not only are carbon fibers very expensive to make, forming them into auto components takes much longer than the few seconds it takes to stamp out metal sheet.

"It's no secret that reducing a vehicle's weight can deliver major benefits for fuel consumption, but a process for fast and affordable production of carbon-fiber automotive parts in large numbers has never been available," said Inga

resin transfer molding (RTM) and sheet molding compound (SMC) methods as well as long-fiber-reinforced thermoplastic processes. Each has its benefits and shortcomings.

Despite the obstacles, car makers are gradually introducing CFRPs into conventional vehicles. The business consulting firm **Frost & Sullivan** predicts that the automotive carbon fiber composites market will grow by a third annually during the next four years. Observers expect that most early commercial applications will be exterior body panels because they can be replaced without altering the basic car architecture. Recent efforts by Ford, **Toyota**, the United States Council for Automotive Research (**USCAR**), and Tier 1 automotive supplier **Continental Structural**

ogy, Ford engineers in Aachen worked with **Dow Automotive** and Hightech. NRW, a collaborative research project in Germany that includes the Institute of Automotive Engineering and the Institute of Plastics Processing (IKV) at **RWTH Aachen University**, **Henkel**, **Evonik**, **Composite Impulse**, and **Toho Tenax**.

The Focus hood is made of a special polymer-foam core sandwiched between two layers of epoxy-infused CFRP fabric. The part is produced using a "gap-impregnation process" developed by IKV that works by injecting resin over a carbon-fiber preform in a slightly open tool, which is then closed to fully wet the fibers before curing. Low-volume production trials at IKV are reportedly targeting a total cycle time of 15 min.

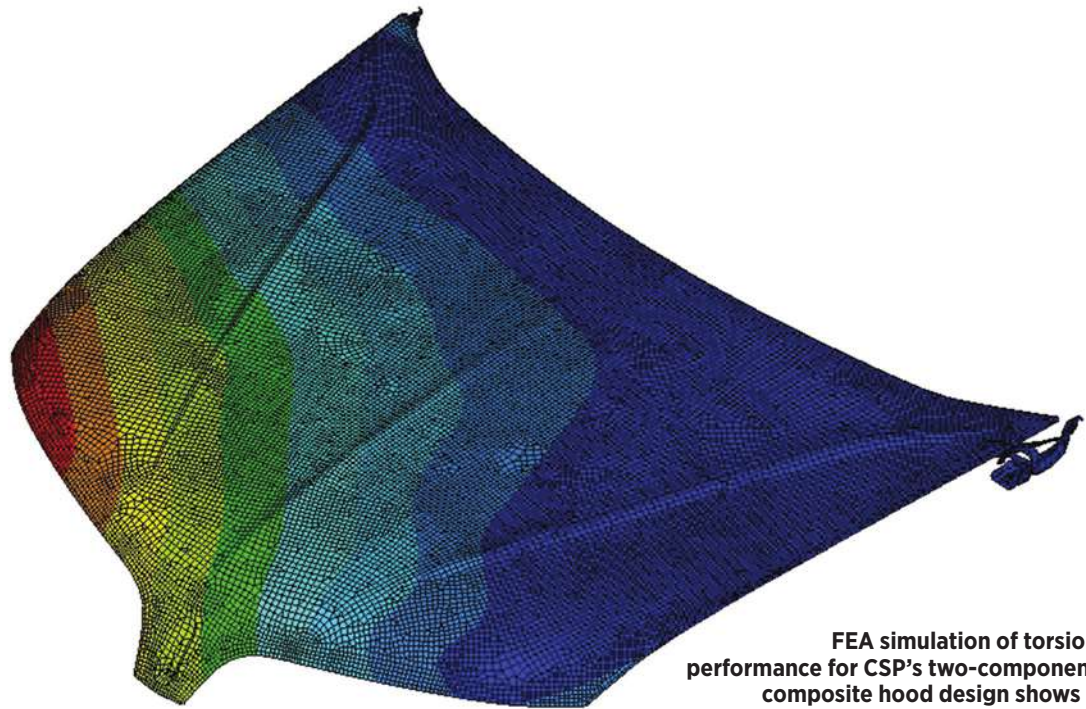
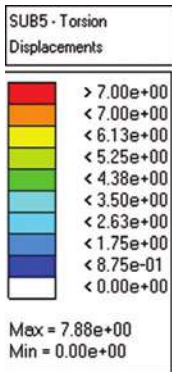

FEA simulation of torsion performance for CSP's two-component composite hood design shows a 30% improvement.

Elsewhere, Toyota announced in January that it had installed a carbon-fiber roof on its Mark X G Sport, a Camry-class car sold only in Japan. The polymer composite panel saves some 6 kg (13 lb) compared to a standard steel version.

Meanwhile, the Automotive Composites Consortium (ACC) of USCAR completed a five-year project to develop a composite floor panel structure for sedans. It also recently began a four-year effort to use composite materials in lightweight but crashworthy front-end structures.

Composites R&D by suppliers

Another company that is pioneering lightweight CFRP body panel technology is CSP, a leading composite products design and manufacturing firm that fabricates both the Corvette C6 and C7 bodies for GM. The company also boasts BMW, **Chrysler**, Ford, and Toyota as customers.

CSP engineers have developed a prototype two-part hood design that comprises an outer face of low-mass glass-fiber-reinforced SMC sheet filled together with an inner structural panel of carbon-fiber-reinforced SMC. The company plans to offer the concept to an automotive OEM for evaluation soon,



Close-up of CSP's prototype inner hood member shows the 1-in (25-mm) chopped carbon fiber used as the reinforcement.

reported Frank Macher, CSP's Chief Executive Officer and Chairman, on a recent episode of the car industry TV talk show Autoline.

"CSP decided to focus on structural lightweighting technology a couple of years ago," said Probir Guha, Vice President for Advanced Research and Development. "But we recognized that we needed expert help, so we hired specialists in surface chemistry and chemical engineering."

The company developed its chops, for

example, working with **Zoltek**, **Huntsman**, and the **National Composites Center** on an ACC-supported research project to develop cost-effective carbon-fiber-reinforced SMC materials and the associated processing techniques for high-volume production. "Through our work with USCAR," Guha said, "we decided to look into other fabrication methods along with partners such as **Toray** and **SGL**."

"About 18 months ago," he continued, "we decided to design our own compos-

TECHNOLOGY

Report



CSP engineers created an experimental tool to form the inner CFRP member of its lightweight hood prototype.



Ford is developing a prototype carbon-fiber hood (partially exposed) for its Focus compact that weighs 50% less than standard steel.



Close-up of Ford's experimental CFRP hood—a sandwich construction—shows the surface before exterior finishing.

ite hood." The prototype hood, he said, has an outer SMC body panel that is substantially less dense than the company's standard SMC formulation because CSP engineers replaced the conventional calcium carbonate filler with mass-shaving glass microspheres. The high-stiffness carbon-fiber-reinforced SMC inner structural panel uses a patented hybrid matrix system of polyurea and vinyl ester.

"The two-part combination saves significant weight—from 20% to 35%," Guha explained. "We're using a mid-density SMC now as a developmental step toward producing hood designs made with low-density SMC that would save 50% or more in weight over standard SMC hoods."

"Initially, we're using 1-inch chopped carbon fibers with loadings up to 45% by volume," said Mike Siwajek, Director of Research and Development at CSP. He described the fibers as "standard grade with some modifications including special sizing to make the surfaces more compatible with our chemistry."

Alternative technologies

"We're also looking at other processing techniques for the inner component such as RTM thermosets, which traditionally have longer cycle times," Siwajek said. "We're looking at ways we could shorten the cycle times, but that work is not as far along as the carbon-fiber-reinforced SMC approach."

Guha noted that CSP is also collaborating with MIT-RCF in Lake City, SC, to use cheap, recycled aerospace-grade carbon fibers left over from aircraft manufacturing. Another in-house research effort is investigating the use of coconut shell fibers as a lightweight filler, which is renewable, inexpensive, and quite effective.

"So far," he concluded, "we've gotten a very positive response from the OEMs. In fact, when we started out it seemed like our goal was very far away, but from what I'm seeing today, I think carbon fiber is close to becoming a mainstream material for a lot of car programs."

Other recent SAE articles related to composites:

<http://articles.sae.org/12529>

<http://articles.sae.org/12056>

<http://articles.sae.org/11854>

<http://articles.sae.org/11722>

<http://articles.sae.org/11618>

Steven Ashley

MATERIALS

Grede offers iron as lightweighting option

Cost-competitive lightweight materials are a significant and relative objective for commercial-vehicle (CV) manufacturers and component suppliers. This focus has expanded significantly in all areas of CV segments, impacting both powertrain and chassis applications. The primary challenge to determine the optimal lightweight material is multifaceted in an effort to meet all imperative load criteria, while simultaneously providing mass savings in a globally scalable, cost-competitive solution.

Grede Holdings presents a comparative analysis of lightweight material options in both strength and cost unit values. Further comparisons qualify the improved value performance of advanced ultra-high-strength cast ductile iron materials such as the Sibodur grades that provide a lightweight and cost-competitive solution vs. the traditional nonferrous cast aluminum materials.

General industry trends reveal that low-density materials such as aluminum, magnesium, and composite derivatives have begun to replace iron and steel. These materials make sense when simply looking at mass density values and typically are the first materials considered in such mass-savings initiatives; however, there can be cost and design ramifications when balancing modulus differences, material strength, ductility, and stiffness.

Mechanical property and cost comparatives

Typically using an aluminum casting vs. an iron casting will result in cutting the component mass by half. Most applications make use of the A300 series aluminum, particularly the hypoeutectic alloys: A356, nominally 7% silicon, 0.35% magnesium; and A357, nominally 7% silicon, 0.55% magnesium. The silicon gives good fluidity when casting, enabling thin sections to be successfully cast. The magnesium provides strength through heat treatment, which also adds considerable cost to the overall manufacturing process in attempts to offer reasonable ductility.

The lowest-cost general-purpose alloy is A356-T6, which is commonly used in many industry applications.

Comparative strength values of cast aluminum, cast ductile iron, cast Sibodur, and cast austempered ductile iron (ADI) materials offer one of the primary determination factors to qualify the material strength parameters for selection of a lightweighting design initiative. A key parameter identified is the limitations of aluminum in both tensile strength and elongation vs. the higher strength characteristics found in the ductile iron derivatives.



Advanced ultra-high-strength cast ductile iron alloys such as Sibodur offer exceptional strength to cost unit ratios as well as part-consolidation potential. A Sibodur front knuckle is shown.

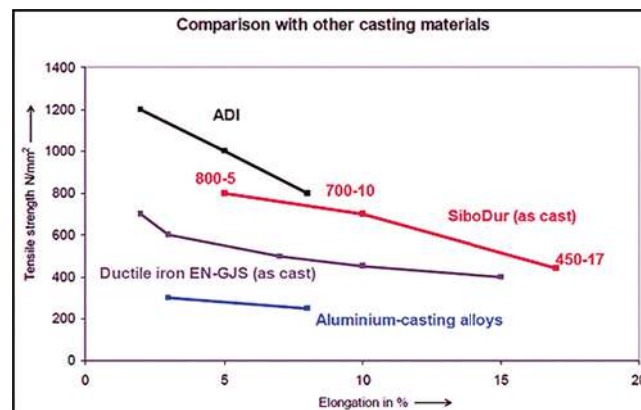

Tensile strength vs. elongation comparatives of cast material options.

The key objective in the material selection process is to match applied structural load criteria to the tensile and elongation values within acceptable safety factors of the design criteria, applied operating environments, and given product life cycles.

Five different Sibodur alloys are available, each offering select chemistries that can improve fatigue strength and functional design optimizations to match the requirements of specific applications. For example, Sibodur's ultimate tensile strength ranges from 450 to 800 MPa, with elongation percentage ratios of 6 to 23%.

Regarding the comparative strength values of these same materials in Rp0.2%-yield stress (N/mm²) vs. elongation % values, again limitations for aluminum are revealed. Limitations of the material selection criteria are imperative to fully consider the dynamic strength characteristics of the material choices, as both tensile and elongation values can be considered as interdependent strength values in the product design and material selection process.

To determine the optimal cost-competitive lightweighting material option,

it is necessary to fully understand and consider the unit strength value of the select material properties with a quantifiable understanding of the associated cost/lb of a given material and its correlating mechanical-property strength value.

The fundamental costs of material options can be evaluated by comparing the true cost/lb vs. tensile unit strength value of measurement. Aluminum A356-T6 market cost position for a traditional high-pressure die cast component carries a cost burden rate of approximately \$2.50/lb, with a defined tensile unit strength property value of about 450 MPa. In comparison, an ultra-high-strength cast ductile iron alloy such as Sibodur 700-10 carries a cost burden rate of approximately \$1.20/lb with a tensile unit strength value of 700 MPa.

With the perspective of material cost valuation, it is prudent to further consider the cost value per lb of mass savings that a given lightweighting program may offer. This cost value of mass savings per lb will certainly vary by a number of basic factors, which largely depend on OEM platform efficiencies and/or governmental mandates driving such initiatives.

TECHNOLOGY Report

Design envelope and component integration

When considering the total cost competitiveness of a lightweight material, it is important to fully consider the design envelope requirements and implications of utilization from one material alloy to another. Further prudence should be taken when considering the total design-for-manufacturing process and integration of mating ancillary adaptive components that comprise the subsystem. Careful examination of the total cost value stream, considering component, manufacturing, and total subsystem integration cost values, is paramount.

That being said, it is critical to understand the implications of the available design envelope that typically expands to accommodate the lower-density materials, such as aluminum, which contain a lower Young's modulus value.

For example, a steering knuckle design that originated from an aluminum die-casting process was transitioned progressively into a higher-density material such as standard GJS450 cast ductile iron material. The design envelope and cross-sectional areas are reduced in overall size comparatively. Additional improvements in reducing the component design envelope and taking additional cast integration of the ancillary brake anchor components and shock tower adaptation features, which were previously considered separate bolt-on componentry, can be realized in a one-piece, ultra-high-strength cast ductile iron solution.

The aluminum design necessitated a much larger design envelope to compensate for deltas of Young's modulus between the material options as compared, and certainly a compensated approach to offset the loss in stiffness was required in the suspension application. By comparison, total cost value stream improvements are possible by utilizing a higher-strength material such as Sibodur 700-10 to achieve part consolidation and streamlined manufacturing operations, as well as overall mass reduction values.

Fundamentally, aluminum offers what is perceived to be mass savings with the delta of material mass density. However, with further consideration to the associated costs for adaptation methodologies required for wheel bearings, brake caliper brackets, and ancillary components, cou-

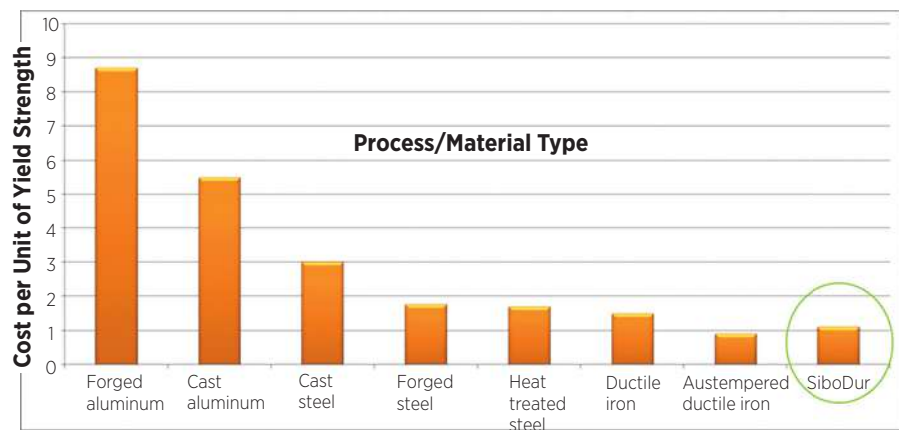

Design evolution of an aluminum front steering knuckle to an ultra-high-strength cast ductile iron material quantifying both integration of ancillary components and reduced mass solutions with Sibodur.

				
Material:	Aluminum	GJS 450	Sibodur	Sibodur
Design:	Standard	Standard	Optimized Version 1	Optimized Version 2
Casting:	2.40 kg.	3.40 kg.	3.40 kg.	4.60 kg.
Bearing:	3.00 kg.	2.65 kg.	3.00 kg.	3.00 kg.
Fasteners:	0.30 kg.	0.20 kg.	0.25 kg.	0.25 kg.
Snap Ring:	0.55 kg.	0.55 kg.	-	-
Brake Shield:	1.80 kg.	1.80 kg.	1.80 kg.	-
Total Mass:	8.05 kg.	8.60 kg.	8.45 kg.	7.95 kg.
Cost Basis:	> \$\$\$	< \$ \$	< \$	< \$
Vehicle Dynamics:	Good	Avg. +	Better +++	BEST ++++

The current market cost/unit strength position for a forged or cast aluminum process carries an exponential cost burden vs. alternative higher-strength alloys when considering yield strength behavior.

pled with the increase in the total design envelope required to accommodate the lesser-strength material, it is commonly found that OEMs have dramatically realized cost inflation to overcome design inefficiencies.

Sibodur handles the load

Commercial vehicles are subjected to a wide range of loads, operating environments, and thermal conditions, which include high shear and bending (due to the vehicle mass and high loads distributed), torsion (caused by irregular roads, putting one wheel on a curb), lateral loading (caused by cornering), and fore and aft loading (caused by acceleration and deceleration). In practice, these load events occur in combination together with both dynamic and transient effects in a wide array of temperature and environmental conditions.

Typically a CV structure will be designed so that under the worst envisaged dynamic load condition, there will still be a factor of safety based on the yield strength of 1.5. This factor is common and usually adequate for guarding against fatigue failure; however, fatigue calculations are still used where stress concentration effects are likely to be significant.

In practice, vehicle design is normally governed by stiffness requirements rather than maximum permitted stress levels.

To maximize Sibodur's capabilities under such conditions, Grede uses topology and FEA to create precise casting geometry to match the individual load case and stress strain vectors exactly where needed, effectively reducing mass and improving fatigue strength.

Truck makers worldwide are using, developing, and testing Sibodur in a variety of components for current and future vehicle programs. These include safety-critical parts with high stress and torque requirements, such as steering knuckles, axles, control arms, hubs, brake rotors, engine mounts, crankshafts, and suspension links.

Sibodur was developed by Swiss-based **Georg Fischer Automotive AG**; Grede has an exclusive license to use the alloy in North America. In addition to the commercial truck industry, the company also plans to supply Sibodur-based castings for cars, light-duty trucks, and industrial applications.

This article is based on SAE International technical paper 2013-01-2419 written by Jeffrey W. Nichols, Director of Business Development, Grede Holdings, LLC.



AVL ELECTRIFICATION SOLUTIONS

Switching Imagination to Reality

AVL Electrification Solutions are the result of the combined experience in designing and developing all different kinds of powertrains, hybrid drives and pure electric drives. By knowing and understanding the five elements of a modern powertrain system, AVL is able

to guarantee that every single part reflects the quality of the entire system. And viceversa. This allows for the perfectly tailored solution for your individual electrification strategy and switches your imagination to reality.
www.avl.com/electrification



TECHNOLOGY Report

AUTOMOTIVE SIMULATION

Federal-Mogul upgrades simulation and testing to meet engine downsizing

Extensive simulation and highly focused testing facilities are proving vital to enable **Federal-Mogul** to successfully keep pace with new demands placed by OEMs on engine components suppliers. The multiple needs to downsize, extract more power via turbocharging and more advanced injection strategies, plus the enduring need to reduce emissions levels, are bringing new challenges.

To help meet these, the company has developed a new, highly optimized casting simulation process called Slow-Motion Casting Simulation (SMCS), which provides more precise data to facilitate the material flow, pressure, and filling of piston ring casting molds.

It is part of Federal-Mogul's Powertrain Segment Division's drive for enhanced quality and stronger, more wear-resistant piston rings. At its Burscheid, Germany, facility, Dr. Steffen Hoppe, Director of Technology for Rings and Liners, said: "The thermal, mechanical, and tribological demands on components around the combustion chamber—particularly piston rings—increases." Engine friction could be reduced by using thinner piston rings, but that meant a stronger material was vital to achieve required bending strength: "To achieve these requirements, we have developed new materials, casting, and simulation processes."

To overcome the limitations of the long-established traditional stack molding process, Federal-Mogul has developed a highly automated vertical casting process that uses a special mold design to optimize the design of blanks and gating systems. The result is said by the company to be markedly improved material flow with feeding around the complete circumference of the casting. It is described as "significantly" improving the uniformity of the graphite formation of the gray cast iron.

SMCS includes the use of a high-speed camera to overcome the limitations of regular finite-element (FE) modeling. Hoppe explained that FE simulation creates a particular hurdle: "No matter how fine a network is selected, the 'macro process' is still simulated. How close the simulation is to reality

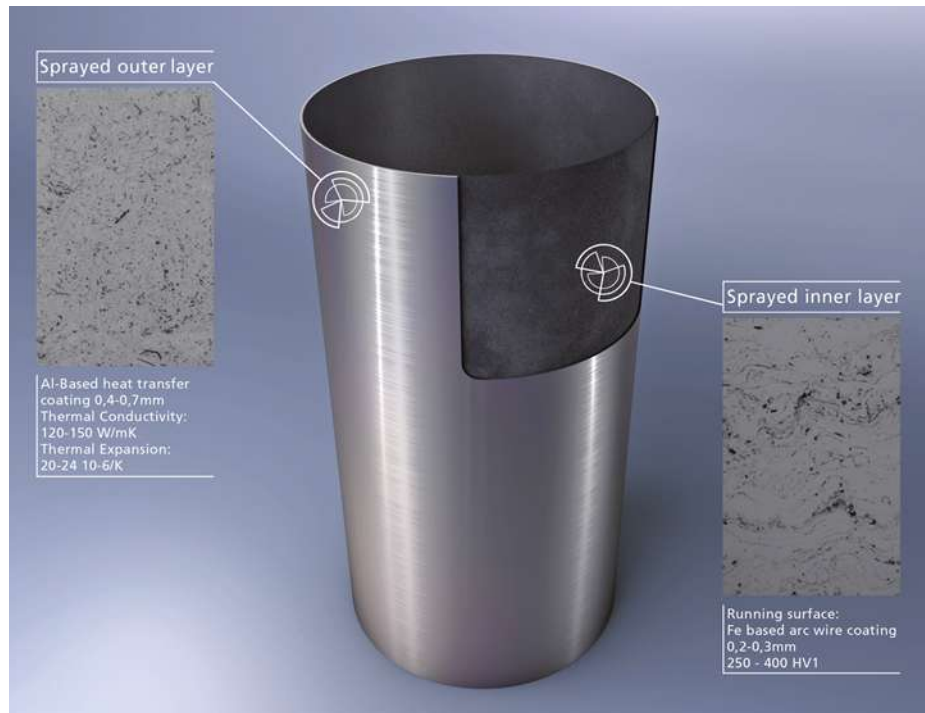

Sprayfit from Federal-Mogul is a very thin liner with a ferrous layer as the running surface and an outer layer mainly of aluminum alloy.

always depends on how well the simulation parameters are chosen and set."

But SMCS is described as overcoming the problem, providing a very detailed analysis of filling the molds and thus facilitating more precise optimization of the complex gating and feed systems controlling molten flow.

The use of SMCS allows the flow behavior of the melt at different temperatures and casting speeds to be tracked more effectively, explained Hoppe. This allows a better understanding of and control of pressure fluctuations and the explosive reactions of the casting process.

Federal-Mogul has also developed a more highly refined casting material. The cast steel (GOE70) has a martensitic matrix structure with embedded chromium carbides and a strength of "at least 1800 MPa." When nitrided, high wear resistance is achieved for particular applications, providing a surface hardness of 1300 HV.

Hoppe believes SMCS will see benefits in both light and commercial vehicle applications.

Testing is also a mainstream discipline at Burscheid. Test House Manager Dr.

Armin Robota said there is growing demand from OEMs for the facility to help improve the performance and durability of engines via its expertise involving critical engine components and their development.

This includes bore distortion, wear, oil consumption, and joint sealing, and Robota believes Federal-Mogul is alone in offering bore distortion measurement in the clamped, unclamped, cold, and hot conditions with simulated heat flow: "We have also developed state-of-the-art methods for oil-consumption measurement including gravimetric techniques, and apply online radioactive tracer technology."

The Burscheid site houses 19 dynamometers, metrology laboratories, and specialist capabilities serving subsystem optimization and the resolution of complex technical issues at product level. Its particular areas of expertise include rings and liners, pistons, rod and crankshaft systems, ignition systems, and the distortion and sealing of block, head, and manifold joints.

Special procedures for cylinder head gasket testing have been developed,



TECHNOLOGY Report

including dynamic gas leakage measurement. An in-house development has achieved a method for removing escaped gas from the coolant system and measuring it directly over the course of an engine durability test. Further test work at Burscheid has included what Robota described as an “exhaustive study” that established the relationship between bore distortion and oil consumption for an (unnamed) OEM, involving a three-cylinder gasoline engine using several liner arrangements. And a V6 diesel was tested using advanced slip ring technology to capture data from pressure transducers and temperature sensors rotating with the crankshaft.



Federal-Mogul's Dr. Steffen Hoppe states that the need to develop downsized turbocharged gasoline engines results in extra demands on combustion system components, particularly piston rings.



Dr. Armin Robota, Test House Manager at Federal-Mogul's Burscheid facility, says there is growing demand from OEMs for its teams' specialist expertise to help support critical engine components' development.

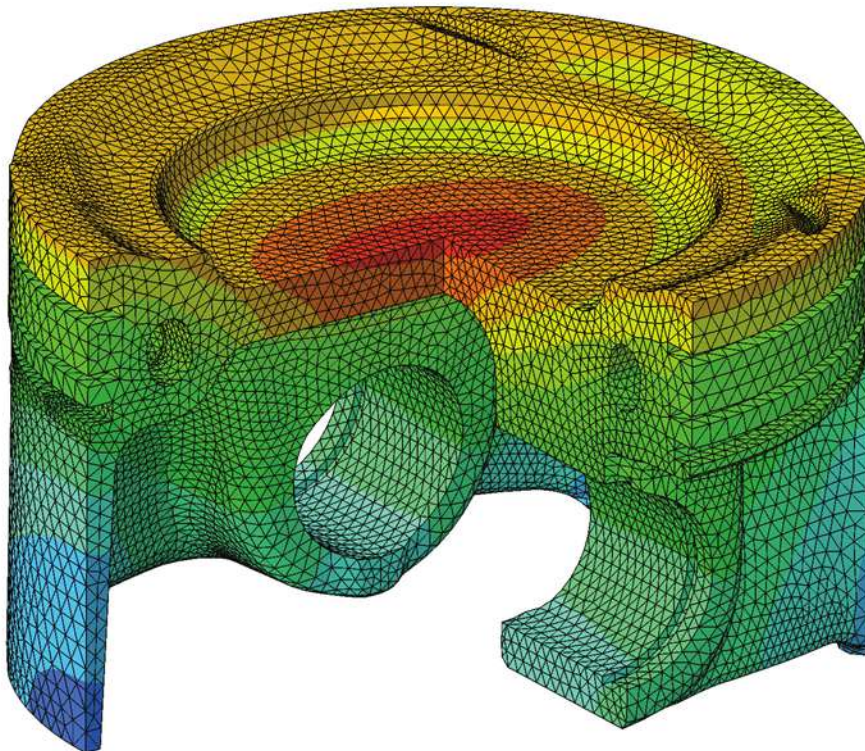

Federal-Mogul's tests have demonstrated that its Elastothermic piston gallery can reduce crown temperature by as much as 25 K to 30 K.

With regard to advances in production, Federal-Mogul's Powertrain Segment has developed a process for cylinder bore manufacturing that combines conventional methods of insert liners with a direct bore coating. Said Hoppe: “Established direct bore coating provides advantages in weight, allows reduced bore spacing, has excellent thermal conductivity, and can provide some friction benefits—but it carries significant challenges in process development, quality, and the required investment.”

The company has developed Sprayfit liners to eliminate these problems. An ultrathin sleeve made of sprayed composite material inserted using a regular press fitting process, it is described by Hoppe as providing greater freedom to develop a liner surface “that is best-in-class for tribology and/or corrosion resistance.”

All this is said to add up to spray parameters that can be optimized without geometric constraints and with “practically no limitations” on liner diameter, length, or wall thickness.

Also new from the company is a piston developed specifically for downsized turbocharged engines. Called the Elastothermic, it has been designed to provide for increases in power density and compression ratio, without refinement or durability penalties. It uses the company's Elastoval gasoline piston architecture but with a cooling gallery higher in the crown of the piston.

The Elastothermic piston is said to decrease crown temperature, reduce the risk of knocking in hotter, higher-pressure power units, while maintaining high structural strength. The gallery cooled piston (tests have shown crown temperatures down by 25 to 30 K) enables downsized engines to run at higher power levels and compression ratios with low NVH but still meet required levels of durability.

Stuart Birch



TECHNOLOGY Report

OFF-HIGHWAY HYDRAULICS | SIMULATION

Modeling and simulating hydraulic circuits

Energy saving is always a topical issue in the off-highway industry due to increasing fuel costs, and, particularly with earthmoving machines (EMM), this aspect is amplified by more stringent emissions regulations that impact off-highway vehicle development. These considerations dictate a continuous strive toward improvements and more efficient solutions. To accomplish such objectives, a strong reduction of hydraulic losses and better control strategies of hydraulic systems are needed.

An efficient way to analyze these issues and identify the best hydraulic solution is through virtual simulations instead of prototyping. To build a hydraulic excavator virtual model, however, some problems relative to different aspects arise. For instance, loads on actuators (both linear and rotational) are not constant and pumps are driven by a real engine whose speed depends on required torque.

Furthermore, the level of detail used to simulate each component of the circuit is extremely important. The greater the detail the better the machine's behavior can be portrayed, but this obviously entails a heavy impact on simulation time. Therefore, engineers must decide the model level of detail to acquire all the phenomena deemed necessary for a correct evaluation of machine performance.

Many researchers have worked on the problem of presenting hydraulic models of EMMs, but always exercised restrictive hypotheses in the course of their studies. For example, some do not treat pump modeling, preferring to address proportional directional control valves (PDCVs) and arm kinematics; others concentrate on pump and kinematics modeling leaving aside the PDCVs design. The influence of hoses and actuators cushioning is often neglected as well as that associated with various hydraulic resistances. Moreover, attention is limited to the arm circuit, forgetting that excavators have other users such as turret swing and travel that are as relevant as the arm circuit.

Following such considerations, researchers from **Politecnico di Torino** have determined the necessary steps to develop a detailed hydraulic circuit

model of a commercial compact excavator. In particular, the entire hydraulic circuit was modeled within the AMESim environment by using both standard and detailed libraries to better describe the circuit. Their work also made use of sim-

plification hypotheses. For instance, modeling of pilot stage valves was not considered, interaction between track and soil was omitted, and turret inertia was held constant during simultaneous movements. However, complex aspects

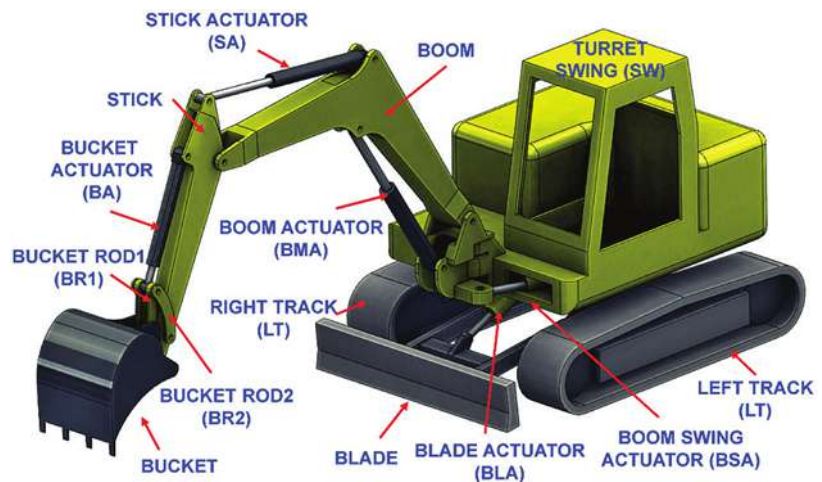

The vehicle under study was a compact commercial hydraulic excavator. It was powered by a diesel engine with a peak power of 50 hp (37 kW).

The PDCV's stack comprised nine modules bounded by an inlet and an outlet section. Starting from the right end side, the inlet section connects piston pump delivery with the LS PDCV's and embodies several valves: an unloading valve, a first check valve that guarantees a minimum pressure level in the T line, a second check valve that allows to by-pass the heat exchanger, and a pressure relief valve that sets an upper pressure limit for the LS circuit.

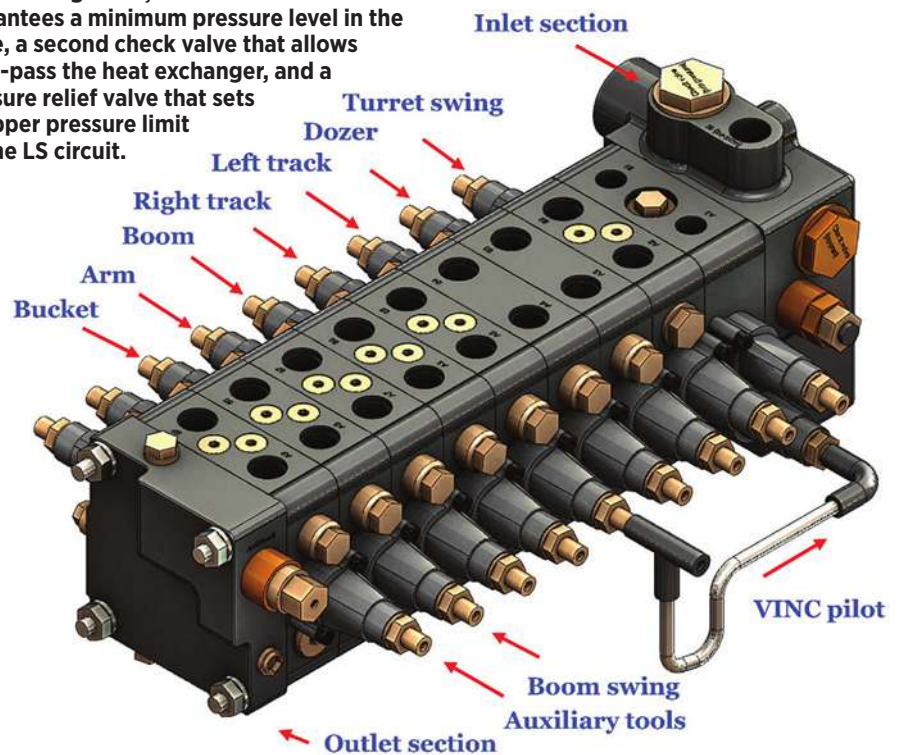

I might not be able to see it...
...but my family relies on it



Brakes India Limited, member of the multi-billion dollar TVS Group is today the largest manufacturer of brake systems in India. With a comprehensive product portfolio covering the car, utility, light, medium and heavy commercial vehicle, agricultural tractor and off-road applications, Brakes India's products are designed to withstand the most vigorous off-duty cycle and are validated to global standards to meet today's increasing customer requirement.

Celebrating 50 years of experience in manufacturing braking products, confirming to the highest standards of quality, reliability and durability, Brakes India has earned the trust and confidence of its customers. In addition to being the leading supplier of brake systems to the leading OEM's in India, Brakes India's genuine brake parts, friction and fluids are sold under the "TVS - Girling" brand through a wide network of distributors covering entire India.

In all probability, your vehicle has a TVS - Girling part in it too!

To learn more about Brakes India and our products, visit us at www.brakesindia.com



Commercial Vehicle
Braking System



Brakes India Limited

urban image

TECHNOLOGY Report

were carefully taken into account, considering the specific application such as modeling the arm's geometry.

Various approaches were investigated. Some used the Planar Mechanical Library (PLM) application within AMESim, while others made use of coupled simulation between Virtual Lab Motion (VLM) and AMESim, where VLM handled the body parts of the excavator. In general, coupled simulation performs well and grants easy settings of parameters, but is expensive in terms of simulation time.

Wishing to limit simulation time, the PLM was chosen to model the arm. In addition, the PDCVs' behavior, mainly in case of flow saturation, must be considered and properly managed to avoid the loss of controllability. This led to an in-depth modeling of PDCVs and of their pressure compensators. As to the pump model, a compromise solution between quality of results and simulation time was achieved.

In fact, attention focused on displacement control devices, simplifying parts relative to flow rate generation. Other valves such as those present in the travel and turret swing were modeled with the Hydraulic Component Design Library. The internal combustion engine accounted for speed variation with torque and the evaluation of fuel consumption to rate the quality of the hydraulic solutions was considered using a fuel consumption map.

Overall, the researchers focused on the analysis and modeling of the whole hydraulic circuit that, beside a load sensing variable displacement pump, featured a stack of nine PDCV modules of which seven were of the load sensing type. Loads being sensed were the boom swing, boom, stick and bucket, right and left track motors, and work tools. The blade and the turret swing did not contribute to the load sensing signal.

Of specific interest were the peculiarities that were observed in the stack. In fact, to develop an accurate AMESim model, the stack was dismantled and all modules analyzed and represented in a CAD environment as 3-D parts. The load-sensing flow generation unit was replaced on the vehicle by another one whose analysis and modeling were developed using available design and experimental data.

Although both the Hydraulic Component Design library as well as the Planar

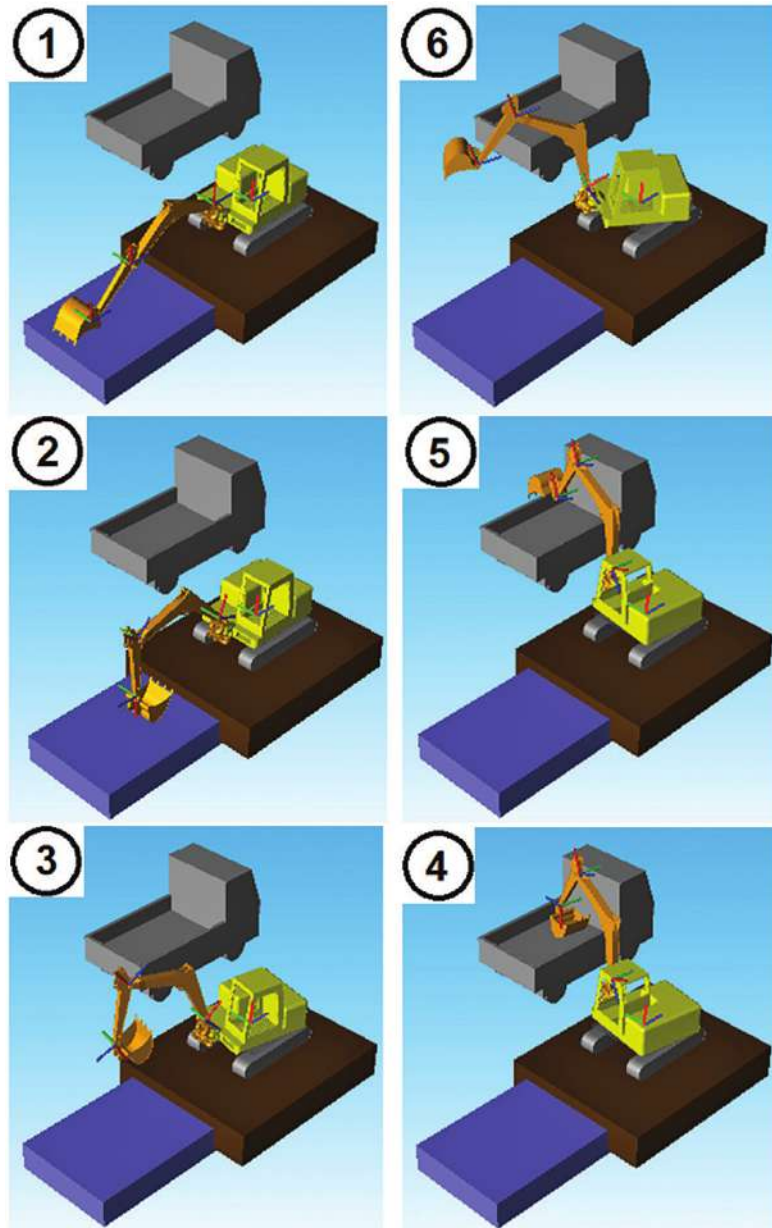

A limited number of frames are shown, taken from a complete virtual animation of the vehicle performing a cycle. This resource can be a valuable aid in checking that performed activities are in fulfilment of what has been planned for the vehicle.

Mechanical library were used extensively in the process of modeling the entire circuit, some simplifications became necessary. As the modeling phase was developing, a number of field experiments on the vehicle were also performed, which served the purpose of providing reference data to the end of progressing with the validation phase of the AMESim model.

Regarding predictive simulation results, those were appropriately consistent with gathered experimental outcomes. The AMESim model will be

instrumental for upcoming analyses that foresee the substitution of the original stack with other load-sensing post-compensated modules to assess with reasonable confidence the effects on potential energy savings.

Future steps are aimed at further modifying the hydraulic circuit by replacing the PDCVs stack to predict potential energy savings.

This article is based on SAE International technical paper 2012-01-204 by Gabriele Altare, Damiano Padovani, and Nicola Nervegna, Politecnico di Torino.



AEROSPACE TESTING

Fine-tuning vibro-acoustic countermeasures in a turboprop aircraft

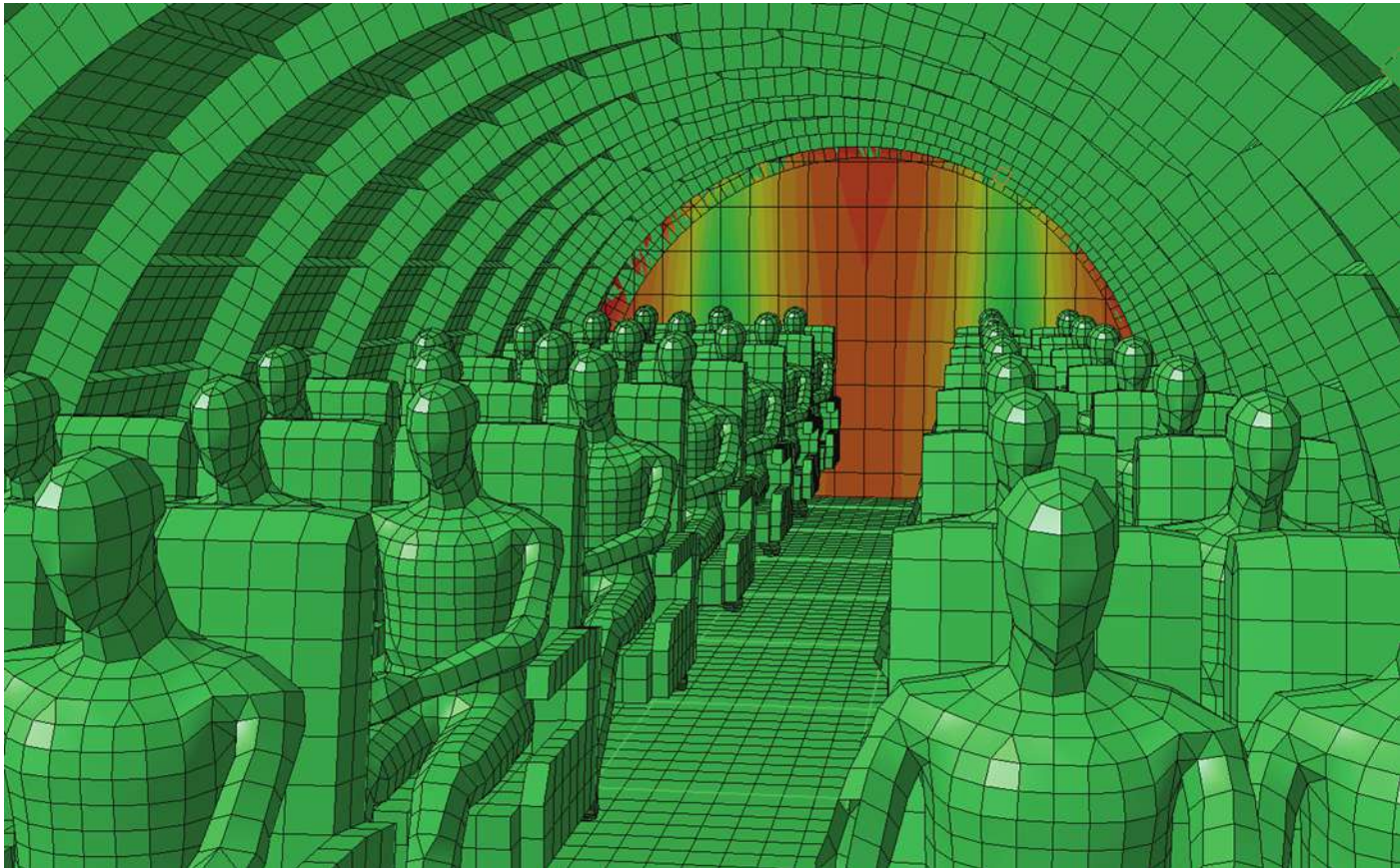

SENER used LMS Virtual.Lab to predict the cabin interior noise due to fuselage vibration.

Turboprop engines are becoming more and more popular because they offer up to 30% reduction in fuel consumption compared to turbofan engines. But turboprop engines are also known for generating substantial noise, so reducing cabin noise to ensure passenger comfort is an important engineering challenge.

“Propeller noise is largely dominated by tonal components associated with the propeller blade passing frequency and its harmonics,” said Pierre Huguenet, noise and vibration engineer at **SENER**, an engineering company that specializes in solving vibro-acoustic problems. Propeller noise can be divided into several categories. Thickness noise is generated by the volume of air displaced by each propeller blade, and its level is strongly dependent on the helical tip speed and the blade geometry. Blade loading noise can be either steady or unsteady. Steady blade loading depends on the propeller net thrust and torque.

Periodic blade loading is caused by oscillations in the blade effective angle of attack that generate acoustic tones. Blade loading noise depends on the blade surface pressure. Finally, quadrupole and nonlinear noise sources are only relevant for propellers operating in transonic and supersonic regimes like high-speed propellers and prop fans. These sources can normally be ignored for a general aviation turboprop aircraft.

Propeller noise can be transmitted to the cabin through the air—the airborne path—and through the structure—the structure-borne path. “The energy from the acoustic waves is coupled with the structure, which in turn is coupled with the interior cabin,” Huguenet said. “This means that we have to deal with an external and an internal acoustic field. Optimizing the cabin noise requires a fully coupled vibro-acoustic numerical model of the aircraft cabin and structure. Depending on the location of the noise

source, sometimes the coupled zone can be reduced to a critical or ‘wetted surface’ area with the largest contribution to the global interior noise.”

A variety of noise countermeasures can be considered such as isolation materials and structural modifications. “If the noise problem is localized, then a possible solution is to make a local structural change to the aircraft panel such as changing its thickness or adding rivets or an attached weight. For a global noise problem, you need to consider modifying the main structure. You might also look at local changes such as adding dynamic vibration absorbers (DVAs), damping materials, or visco-elastic materials.”

“Making structural changes and adding isolation materials can reduce the perceived cabin noise level by up to 15 dB,” Huguenet said. “Active control techniques interacting with the noise source can provide further noise reductions, but



TECHNOLOGY

Report

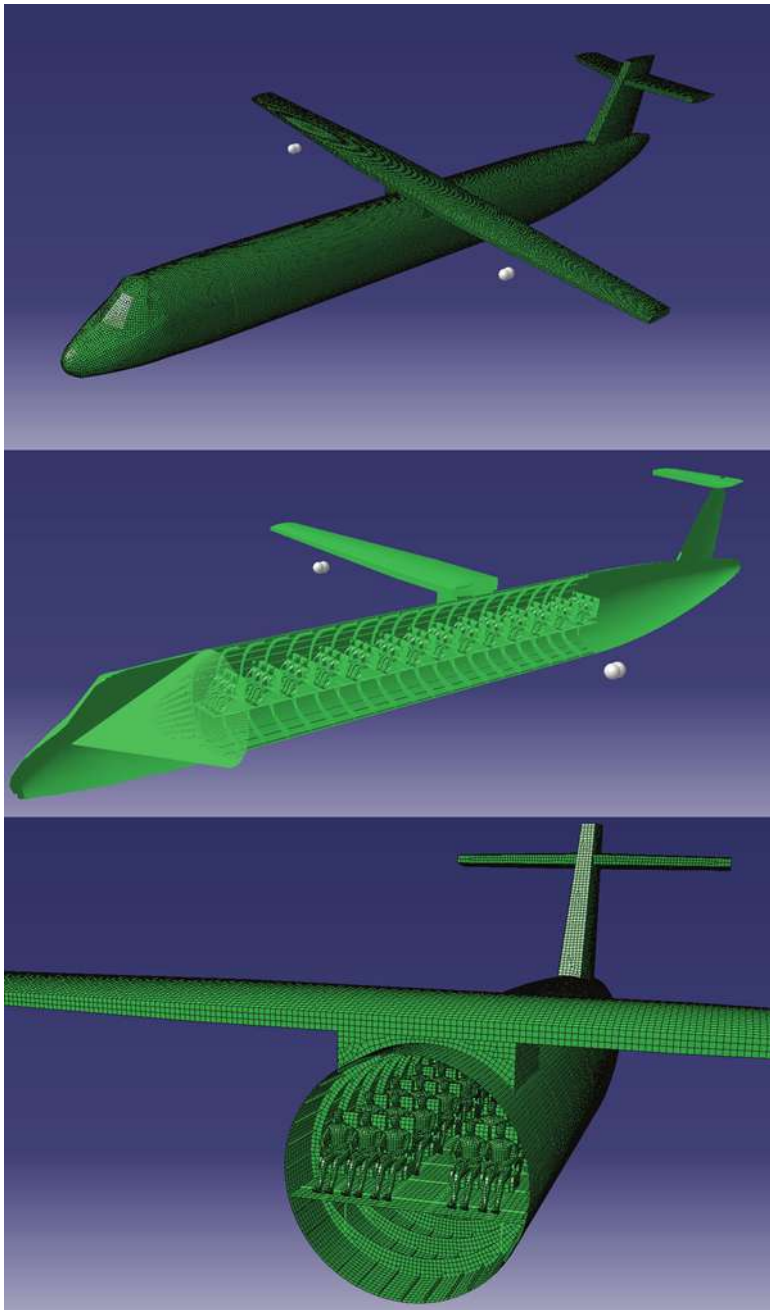

Examples of different meshes used in LMS Virtual.Lab to optimize noise countermeasures.

these methods are rather complex and can also be expensive.”

The simulation process needs to encompass both the acoustic field and the structural response at the frequencies of interest to solve coupled vibro-acoustic problems. “In our most recent project on a turboprop aircraft, the model included a detailed finite-element model [FEM] of the fuselage structure and a representation of the interior and exterior acoustic domains using boundary elements [BEM],” Huguenet said. “Coupled vibro-acoustic simulations

were performed with **LMS Virtual.Lab**, focusing on the first blade passing frequency (BPF).”

In the case of a turboprop aircraft, SENER focuses on BPF tones generated by the turboprop engine covering the low and mid frequency range, the harmonics of the BPF tone, and possible false harmonics. Low frequencies for a turboprop aircraft range from 10 to 200-250 Hz and mid frequencies from 250 to 400-500 Hz. A statistical approach such as Statistical Energy Analysis is used to study frequencies higher than 500 Hz.

“Vibro-acoustic problems are solved by using FEM for the structure and either a FEM or a BEM for the acoustic domain. The choice between FEM/FEM and FEM/BEM depends on the size and complexity of the model and whether the problem is interior or exterior. FEM/FEM models require a full mesh, yet the matrices are sparse so large models can be efficiently solved. A coupled FEM/FEM model is usually preferred for interior problems. FEM/BEM models, on the other hand, have less elements in the BEM mesh so the model creation and modification are much faster.”

SENER has developed a specific methodology to perform a two-step sensitivity analysis, which provides a greater understanding of the vibro-acoustic countermeasures, optimization of the countermeasure distribution, and a more efficient solution for weight reduction.

“LMS Virtual.Lab includes a number of analysis tools and toolboxes that are very useful for this type of analysis,” Huguenet said. “We have used LMS Virtual.Lab concurrently with Nastran SOL 200 to perform a sensitivity analysis of the baseline configuration. Sensitivity analyses help to determine which countermeasures are effective and which are not.”

“The goal of the optimization is always to minimize the amount of countermeasures without compromising the amount of noise reduction,” Huguenet said. “When you increase the stiffness of 10 panels, it will reduce the local noise level. This can be a good solution, but it may not be the best one. Maybe increasing the thickness of only nine panels would be only 0.01 dB noisier yet 20 kg lighter. Sensitivity analysis helps us optimize these trade-offs.”

“Given the demand for more economical aircraft, the ability to optimize countermeasures is important,” Huguenet said. “We use a hybrid approach with a brute force mathematical optimization as a first step and a second more subtle optimization step to fine-tune the solution without losing too much sound reduction capabilities. When you are able to remove 10 kg of DVAs with only a 0.2 dB loss, that’s nearly always a good trade-off.”

Jennifer Schlegel, Senior Editor, LMS International, Leuven, Belgium, wrote this article for Aerospace Engineering.



At the forefront of ground vehicle standards development.

Then and now.

The first engine oil viscosity standard and the introduction of engine horsepower ratings. The influence of motorcycle headlamps and rollover protective structures for tractors. A standard that defines electric-vehicle charging couplers and the creation of those to aid in the development of the Smart Grid.

For over 100 years, SAE International has played a critical role in the progress of the automobile and the ground vehicle industry.

And while the work of engineering today's vehicles may on the surface look very different given the complexity of technology and global markets, SAE International and its standards development program have essentially remained unchanged. It continues to provide a neutral forum for collaboration on common engineering challenges and the creation of standards, thereby helping industry reduce costs, increase productivity, improve market position, and advance new technologies.

Whether it is bringing standards for and from the United States market to the global table or serving as the world's center of expertise on Commercial Vehicle/ConAg standards, SAE International is uniquely positioned to provide innovative standards solutions—be they by consensus, consortia or harmonization—that offer industry, companies, and individuals opportunities to influence, grow, and prosper.



SAE 10W-40
MOTOR OIL



SAE J1772™

P110789

Automotive Headquarters
+1.248.273.2455
www.sae.org

Technologies for safe, green, and connected vehicles

Developing and retaining a pipeline of engineering talent, complying with expanded regulations, and staying competitive in an increasingly global market are driving transformation and growth in the mobility engineering industry. OEMs and suppliers continue to find ways to maintain profitability despite the ambiguity and uncertainty of current business and economic conditions, cyclical trends, and massive compliance pressures.

The mobility engineering community is addressing these challenges and opportunities by concentrating on emerging and enabling technologies that attract desired talent, assist in meeting regulations, and provide a sustainable competitive advantage in their market space. Furthermore, global platforms are being leveraged, contributing to profitability by satisfying customer requirements at lower development costs. Globalization has offered a new twist by requiring individual companies to figure out how best to create a competent and efficient global technical network, which is no easy task.

In an attempt to assist companies and individuals facing these challenges, SIMCOMVEC 2013 (<http://simcomvec.org/>) is being offered as a joint effort by **SAEINDIA** and **SAE International**. Combining the 8th SAEINDIA International Mobility Conference with the inaugural Commercial Vehicle Engineering Congress India, SIMCOMVEC features a solid technical program, unparalleled networking opportunities, innovative products that will be on display, as well as an accompanying ride-and-drive experience.

Technical content is the primary reason delegates will converge from across the globe on the Chennai Trade Centre over December 4-7, 2013. With a theme of "Technologies for Safe, Green, and Connected Vehicles," 40 technical



Ashok Leyland is the event sponsor of SIMCOMVEC (U-2523 T shown).



Bharat Vedak



Tom Stover

sessions (<http://simcomvec.org/programme-schedule.php>) will examine critical topics for the on- and off-highway engineering community.

These topics include emissions control, alternative fuels and propulsion, vehicle architecture and communication networks, safety systems, vehicle energy management, telematics, simulation, modeling, virtual prototyping and testing, standards and regulations, onboard diagnostics, prognostics, and frugal engineering concepts and best practices.

Integrated into these technical sessions are business and process considerations that are essential in any successful global business today. Knowledge sharing coupled with diverse perspectives on common challenges and potential solutions are the key ingredients that differentiate SIMCOMVEC from other events.

International speakers from leading companies will share their insights with SIMCOMVEC delegates and include Thomas Stover, Vice President and Chief Technical Officer, Vehicle Group, **Eaton**; Jorg Lutzner, Head Services & Commercial Vehicles, **Continental Corp.**; Walter Lucas, Vice President, Commercial Powertrain Systems, **AVL**, Austria; and Bharat Vedak, Vice President, TCI and Deliver Customer Value, **Deere & Co.**

Vedak is active in SAEINDIA and SAE International and offers a distinct perspective to the importance of the collaboration of these two professional engineering societies.

"Now more than ever, it makes perfect sense for SAEINDIA and SAE International to collaborate on SIMCOMVEC," said Vedak. "Beyond the obvious benefit of each entity improving brand identities, the engineering community is the real beneficiary. The horsepower SAEINDIA and SAE International collectively bring to this event will help our industries gain a deeper understanding of local and global customer and stakeholder needs. This is especially critical in the areas of frugal innovations for value-conscious customers and speedy engineering competency development for an increasingly more global technical workforce." ■

Greg Muha

Q&A with Dr. Pawan Goenka



The Executive Director & President—Automotive & Farm Equipment Sectors, Mahindra & Mahindra Ltd. answers questions on a range of subjects such as auto fuel efficiency, emissions, alternative fuels, safety, telematics, manufacturing, and sustainability.

On design of passenger vehicles, what are the new technologies you foresee for better fuel efficiency?

Sustainability is by far becoming the single biggest challenge facing the automotive industry. All emerging technologies that will make a meaningful contribution toward enhancing sustainability of the automobile in both manufacturing and in its usage are gaining prominence.

There are many technologies—mature as well as emerging—that are being considered by auto manufacturers, and each technology comes with its own advantages and cost implications. For a country like India where an affordable mobility solution is a key criteria, the challenge is to strike the right balance between technology and affordability.

Some quick hits that will deliver good result on the vehicle side are:

- Weight reduction through design optimization, use of light-weight materials (materials substitution), and a systems approach to design
- Aerodynamic styling that will deliver a lower drag coefficient
- Friction reduction technologies such as, low-friction bearings, lubricants, cross-flow cooling, crank offset, variable oil pumps, and low-resistance tires.

The second category includes technologies that will take time to deliver and are relatively expensive like:

- Engine downsizing
- Engine weight reduction—oil module, EGR module, plastic cam cover, plastic manifold, aluminum crank case, etc.
- Increased electronic content as an aid to create driver advisory for better performance from the vehicles.

Then there are technologies for the long run that will need more time to develop and improve affordability, which includes electric vehicles, hybrids, and fuel cells.

From the nonvehicle perspective, factors such as fuel purity, road conditions, and congestion have a significant impact on fuel efficiency. Our country at large, and the auto industry in particular, will need to evolve a long-term road map.

Do you think the influence of human activities on environment is as adverse as projected? What are your views on moving to the next stage of emission norms?

There is scientific evidence that proves human activities have an adverse impact on the environment. Whether they are related to urbanization, commercialization, infrastructure development, or power generation, all come with their own share of constraints and strains on the environment. It is an inevitable outcome that follows progress. However, efforts have been put in place to control and minimize the impact.

Q&A with Dr. Pawan Goenka



In March, Mahindra revealed its all-electric, zero-emission e2o at India Gate in New Delhi with a range of 100 km (62 mi), making it ideal for city driving.

The automotive industry has been and continues to be a responsible industry. Over the past few years, we have incorporated many technologies to reduce the environmental impact of automobiles, both in terms of their usage and manufacturing processes.

On the emissions front, the Indian auto industry, in particular, had a late start compared to its global counterparts but has been very quick to catch up. Today, we are just about four years behind the Euro norms. Going forward, the Indian auto industry supports better emissions standards but seeks government support to lay out a road map that will further facilitate the industry to plan and develop appropriate technologies.

As of today, we have dual emissions norms. The 13 metros follow BS IV, while the rest of country is at BS III. Efforts should be made to move toward uniform emissions norms across India.

What is the future of alternate-fuel technologies for automotive applications, what are the technologies that are promising at the moment, and how do we progress to make these technologies commercially viable?

Compressed natural gas/liquefied petroleum gas (CNG/LPG) fuel options are already available in major cities serving as alternative fuels. However, there is a strong need to proliferate these options throughout India. Distribution challenges do exist, but with the necessary efforts and determination, these can be overcome.

The next big opportunity is with battery EVs, and we at Mahindra see its great potential for India. The government has, in a way, echoed our belief through the launch of the National Mission for Electric Mobility. It is with this belief that we recently launched the Mahindra e2o, which is Mahindra Group's answer to the pertinent issues of climate change, energy security, rising oil and gas prices, as well as pollution-related health concerns.

To make EVs commercially viable, the government needs to encourage the development and use of EVs through incentivizing the purchase of EVs, setting up charging infrastructure, and encouraging OEMs to develop EV technologies in India. The OEMs also have a role to play in making EV technology more affordable.

Apart from safety regulations and considerations in designing and manufacturing vehicles, what approach would you suggest for India in terms of improving safety on Indian roads?

Unfortunately, India ranks very poorly when it comes to road safety. A very high proportion of accidents (78%) are caused by fault of driver and other road users. Hence driver awareness and education will play an important role in enhancing road safety.

In addition, we need to focus on improving road infrastructure, for example provision of footpaths, adequate illumination, and road quality.

Other important initiatives would be implementing a good-quality vehicle inspection and maintenance program, enforcing stringent monitoring of speed and loading limits, and leveraging information and communication technologies that improve emergency care for on-road accident assistance.

In your opinion, what are the areas India must focus on manufacturing competence improvement compared to China, Brazil, Russia, and South Africa?

My aspiration for the Indian automotive industry is to earn a reputation of consistently designing and delivering world-class mobility solutions. Backed by our design, development, and manufacturing capabilities across the automotive value chain, the 'Made in India' label should eventually become an aspirational brand in the global automotive space.

Quality will be the main differentiator that will enhance the 'Made in India' brand. For delivering manufacturing quality, a skilled workforce is a key enabler. Today, our skill competence is relatively low as compared to global standards, as evident from the recently concluded World Skills competition at Leipzig. Furthermore, we do not have adequate number of technically competent people available for the auto industry for both OEMs and suppliers. So, skill building needs to be a focus



Launched in October 2011, the Mahindra XUV500 made its global debut in Pune, India, starting at a low price of Rs.10.80Lacs with technology and refinement like never before seen on an Indian domestic SUV.

area for the industry, and this will be realized through the initiatives laid out by ASDC (**Auto Skills Development Corp.**).

Today India is also associated with a low-cost tag. This is a position that is neither desirable nor sustainable over a long period. More than just cost, the focus needs to be on delivering lowest per-unit cost of innovation.

Hence, a focus on quality, skills, and lowest per-unit cost of innovation will give Indian manufacturing a competitive advantage and enhance brand image.

Can you tell us about the advantages and benefits of developing and introducing telematics and vehicle connectivity?

There are several advantages and benefits of introducing telematics and vehicle connectivity. In the future, these technologies will contribute to leveraging the existing urban infrastructure and also deliver value to the customer in the form of seamless connectivity and convergence of lifestyle and mobility needs.

Some examples of such technology applications are traffic management in cities as well as collection of toll and parking fees. On a wider scale, there will be options of integrated public transport systems and fleet management.

What enablers do you think that the government, industry and others should look at in creating and sustaining demand in automotive sector?

For a developing and geographically diverse country like India, the need for mobility will

only increase with time. The real challenge lies in converting this need to demand for automobiles.

The most significant contributor to creating and sustaining automotive demand is economic growth and socio-political stability. However, this is not the context of this discussion. Beyond this, the government and industry each have an individual and joint role to play.

The government needs to lay out stable policies for the automotive industry that encourage OEMs and auto component manufacturers to invest in technology and capability building. Adequate infrastructure is another focus area, be it intercity or intra-city connectivity. Taxes on automobiles need to be reconsidered, as today automobiles perhaps attract the highest duty rates among all consumer products.

In certain situations, the government also needs to consider providing a stimulus package to the industry and also consider providing incentives for fleet modernization, which has a positive impact on the environment and energy security.

For the industry's part, investments are needed toward enhancing sustainable technologies, developing affordable mobility solutions, and offering a varied product range that caters to diverse customer needs.

How do you rate the success of XUV in terms of its acceptance in the market?

By far, XUV500 is our most successful launch in recent times. The product has been really appreciated by our customers, and in the initial months of launch we could not meet customer demand. If one looks at the industry segmentation and numbers, XUV500 in a way has driven the growth of the premium SUV segment in India. Even today, which is 26 months after launch, demand continues to be strong.

For us at Mahindra, XUV500 means a lot in terms of maturing product development capabilities. It is the first monocoque vehicle designed by us and also the first product developed at our new development center at Chennai called MRV. We have also introduced many new technologies. It may very well be the first four-wheeler entirely styled in India by Indian designers. Overall, it has strengthened the Mahindra brand in the eyes of the customers and industry alike. ■

Advances in surface engineering



Newer materials with improved properties can enhance the properties of the working surfaces of cylinder components for the demands of increased temperatures, pressures, and corrosive atmospheres and still satisfy performance and life requirements.

by Dr. R. Mahadevan, India Pistons Ltd.

By all accounts, the internal-combustion engine will continue to play a major role as the prime mover for automotive vehicles for decades to come. It has faced a lot of challenges in the past, but it is also true that at every challenge, the industry comes up with an adequate response to meet that challenge in part or in full.

Higher specific output, tighter emission norms, CO₂ reduction through better fuel economy, longer life, and affordability will remain as persistent demands from the engine designer in the foreseeable future. The order of priority may change, influenced by factors such as fuel and oil prices, state of infrastructure, customer preferences, legislation, resale value, etc.

Central to the response from the component designer to these requirements is the constant search for newer materials with improved properties. Quite often one finds that while the base material meets the

strength and durability requirements, the working surface suffers from incompatibility with the mating surface or tends to suffer from irreparable damage leading to failure.

Surface engineering has provided an answer to these deficiencies by enhancing preferentially the properties of the working surface. Cylinder components, which have to bear the brunt of increased temperatures, pressures, and corrosive atmosphere and still satisfy performance and life requirements, have benefited greatly from recent advances in surface engineering.

Surface engineering includes diffusion treatments, overlay coatings, and surface modifications that are primarily aimed at improving wear, corrosion, and scuff resistance, as well as coefficient of friction.

Surface modification and diffusion result in a thin modified layer that has the improved properties, whereas in overlay coatings there is an interface present that distinguishes the coating from the parent material. The reciprocating piston and ring assembly and the corresponding cylinder bores are the best examples of components that have benefited the most from advances in surface engineering.

Dry-film coatings

These are generally applied on piston skirts, engine bearings, journals, valves, and pushrod assemblies. These contain molybdenum or tungsten disulphide and provide surface lubricity that protects against friction, galling, and wear. In some cases, they have the ability to hold oil and prevent oil film being pushed out of mating surfaces.

The piston image shows a typical piston whose skirt has been screen printed with a MoS₂-containing thin film. Mechanical friction arising from the piston/bore interface is known to decrease over a considerable part of the working life with such coatings. Polymer-based coatings are also being employed as friction-reducing agents subject to their ability to withstand the working temperature.

Thermal barriers

Thermal barriers applied on piston crown and top land, combustion chamber, exhaust valve port, and manifold are coatings generally containing high percentages of ceramic ingredients. These help to reduce heat absorption by the base material of the component and keep the parts operating at a cooler temperature. This area of research received a lot of attention in the past, particularly in the context of

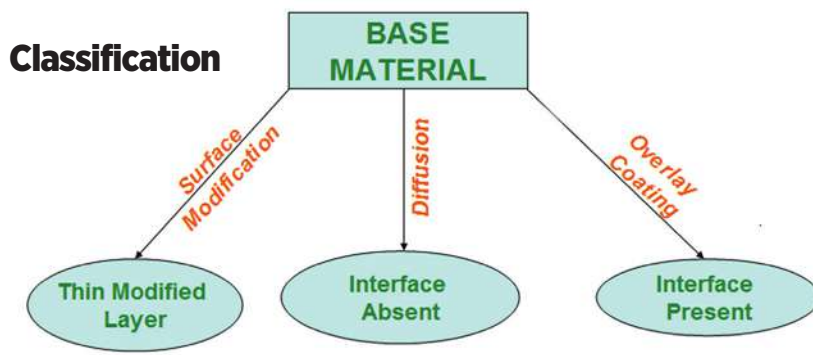

Surface engineering methods.

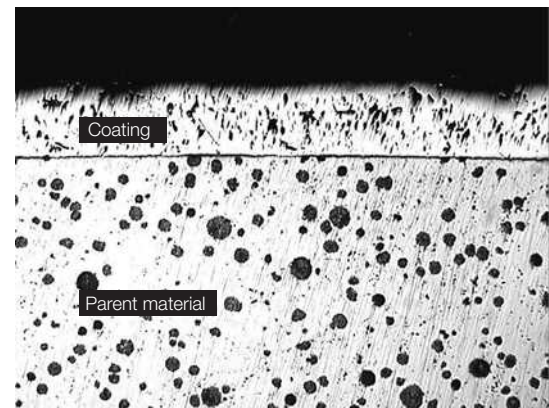
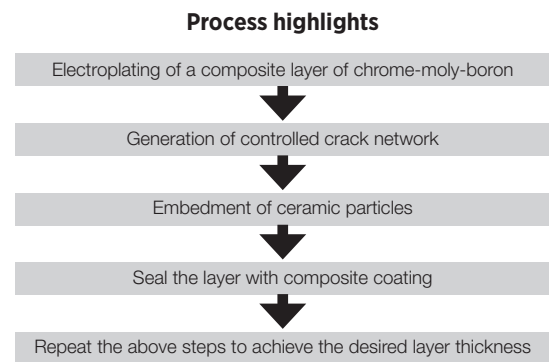
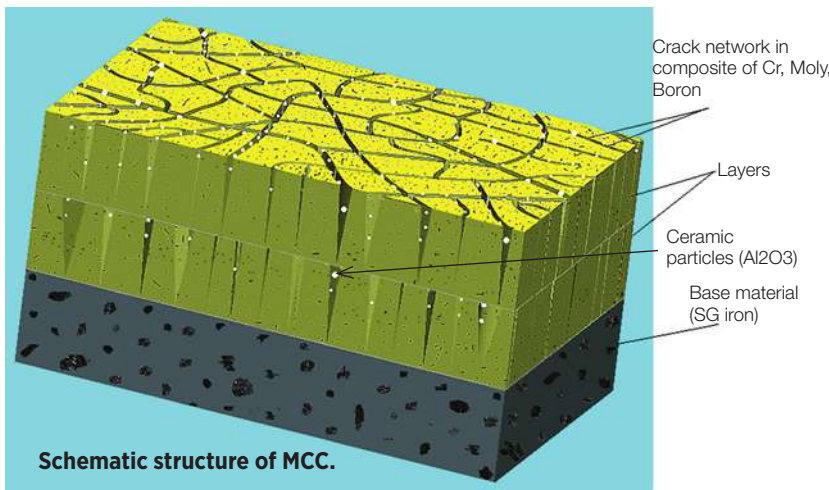

Cross section of MCC at 100x.

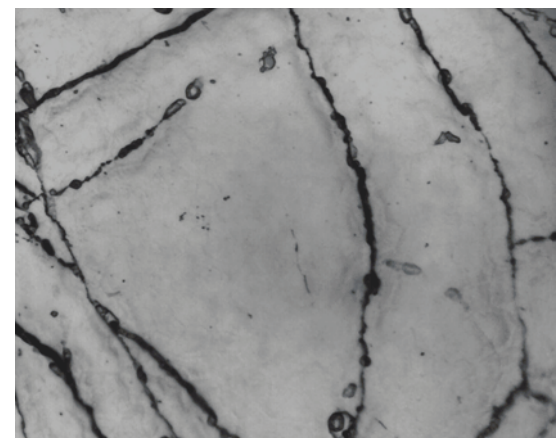

NDC coating surface at 1000x.

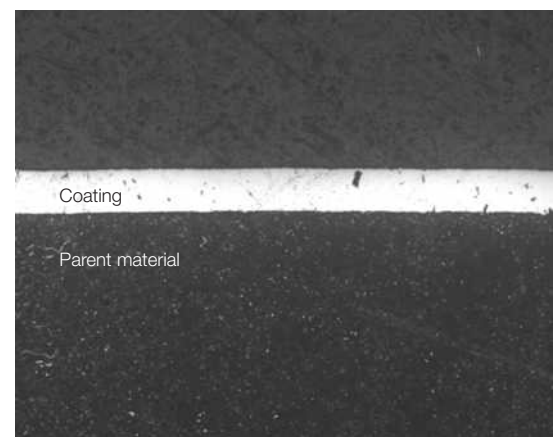

Typical cross section of NDC at 100x.

adiabatic engines, which later waned due to durability concerns and energy recovery issue.

The piston ring peripheral surface and cylinder bores have received special attention from designers for improvement of their running properties. Heat treatment or surface modification only provides limited solutions. For example, heat treatment of cast iron rings and liners and nitriding of steel rings and steel liners have been employed in heavy-duty diesel engines for improvements in strength and wear resistance. However, surface coatings have now become an integral part of cylinder component design by virtue of the higher hardness and thermal properties one can achieve for improved wear and scuff resistance. Some of these coatings are described below.

Types of coatings

Hard-chrome plating by electrolysis and molybdenum coating by plasma spraying have been known in the industry for a long time. Hard-chrome plating provides a base reference for wear and scuff resistance against which other coatings are compared. Molybdenum provides exceptionally good scuff resistant surface but suffers somewhat in terms of wear resistance. Plasma spraying, however, provides the flexibility of using a mix of metal powders than can be sprayed to enhance specific properties.

Composite coatings

Development of a hard-chrome coating with embedment of ceramic particles (Al₂O₃) in multiple layers provided the next big step. Major manufacturers of piston rings have their own version of chrome ceramic coatings. A further improvement came along with the development of moly chrome ceramic (MCC) coating with added scuff resistance to the



Advances in surface engineering



PVD furnace and equipment.

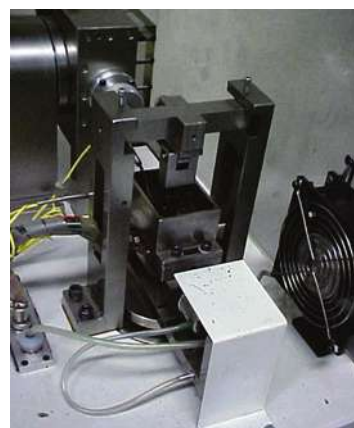

Reciprocating wear and friction monitor.

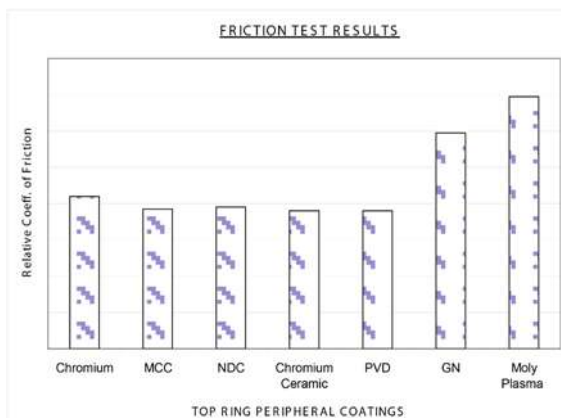
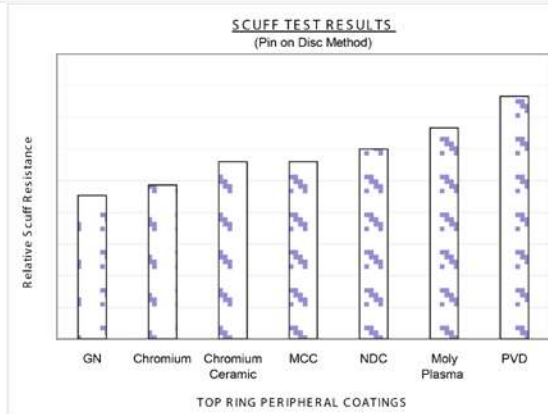
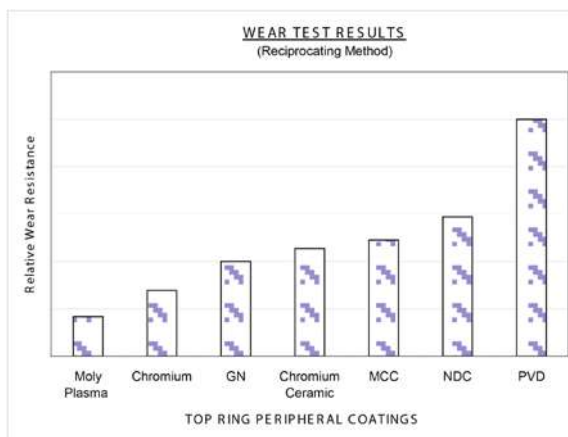

These bar charts show relative top ring peripheral coating properties, with chrome as a reference.

already high wear resistance. The process essentially is pulse electroplating for which chrome, molybdenum, and boron are co-deposited and ceramic particles are embedded in a specially developed crack pattern in multiple layers.

Diamond coatings

Further improvement in wear resistance of piston rings can be obtained by employing diamond instead of ceramic particles for embedment in specially developed cracks. In a variant of the diamond coating developed by the author's team, nano-diamond particles are co-deposited with chromium and molybdenum by a unique electroplating technology wherein ultra-high dispersion of nano-sized spherical diamond particles are embedded, leading to a highly wear- and corrosion-resistant coating. Multiple layers of such nano-diamond composite (NDC) plating are employed to achieve the desired coating thickness.

Diamond-like carbon coatings (DLC) have been applied to piston pins, piston ring peripheries, and cylinder bores for improving wear resistance. Physical-vapor deposition (PVD), plasma-assisted chemical vapor deposition (CVD), or a combination of both have been employed for applying these amorphous carbon coatings.

Physical-vapor deposition has now provided a method of depositing very hard coatings from the vapor phase onto the surface of piston rings. Very thin coatings, as low as 20 microns of chromium Nitride for instance, can provide exceptionally good wear and scuff resistance with the advantage of lower friction compared to conventional coatings.

Comparison

A specific test rig, in which ring samples with designated coating can be reciprocated at various loads with varying frequency at different temperatures in flooded lubricating conditions, was designed and fabricated for comparing the various coatings. An optical profilometer was used to assess wear figures for relative comparison of wear, scuff, and friction coefficient tested against cast iron plateau honed liner surface.

The accompanying three bar charts show relative properties, with chrome as a reference, and indicate how surface coatings have progressively been developed to meet the requirements.

In conclusion, there are several options that are available to the designer to choose the most appropriate surface engineering methods, which in combination with a standard base material can meet the engine performance requirements. Continuous research is going on in further extending the boundaries of usage of presently known materials with newer surface engineering techniques by way of coatings and surface modification. ■



BE AN AUTO INDUSTRY LEADER – ENGAGE WITH ONE.

Discover SAE's full menu of solutions that meet the needs of your organization, including ...

- **SAE's Digital Library** is the complete collection of automotive engineering information for technology research worldwide, including standards, papers, scholarly journals, e-books and other relevant industry publications.

Try it free for 2 weeks at saedigitallibrary.org.

- **SAE Subscriptions** are designed for companies, organizations and individuals who routinely need the most current information on key topics in mobility engineering.

For more details, visit subscriptions.sae.org.

- **SAE's Global Technology Libraries** select and aggregate valuable SAE-generated and industry-partner content covering vehicle electrification and alternative fuels and make it available to your enterprise system in an online platform that enables you to browse, search and share content quickly and easily.

Get a free 2-week trial at saegt1.org/ev for electric vehicle or saegt1.org/af for alternative fuels.

Visit engineering.sae.org/autoindustryleaders for a complete list of products and to see why auto industry leaders engage with SAE International.

1-888-875-3976
www.SAE.org



E-mobility opportunities in the Indian ecosphere



The Prime Minister of India in January 2013 unveiled the National Mission on Electric Mobility and formed a National Board of Electric Mobility to fast track e-mobility for India through industry-government partnerships.

by Dr. Arun Jaura, Board of Directors, SAE International; Chairman, Automotive Board, SAEINDIA; and MD & Founder, TRAKTION Management Services Pvt. Ltd.

The changing customer paradigm is challenging today's mobility practitioners and transportation solutions industry to revisit their assumptions in developing solutions that provide an opportunity for electric mobility (e-mobility). With fluctuating oil prices a continual reminder of limited oil resources, today's consumer and economy are skateboarding the anxiety wave. An optimal blend of innovation, technology, and processes along with effective policies and regulations is required to achieve success in e-mobility.

Is the Indian customer ready for e-mobility, and how affordable will it be? In the Indian context, the requirements and usability patterns are very different compared to the mature markets. The innovative solutions and the mind-set to develop them have to be very different in the Indian context.

A study was conducted on the driving pattern in four major metro areas between two given locations at different times during the day. It was observed that, on an average, the vehicle stopped every 400 m (1300 ft) in traffic, and the average speed was only 10 to 15 km/h (6 to 9 mph).

Interestingly, this study pointed out that the driving speed of a vehicle and customer needs in Class A, B, or C cities are very different. Today in Indian e-mobility, the launch speed and highway driving pattern that is seen in advanced markets clearly does not exist. The range required is limited since the driving distances are typically below 30 km (19 mi). In the Indian context, high speeds in metro driving are rare due to traffic congestion. Thus the consumer does not need a 100-km (62-mi) plus range and does not feel the need to achieve 0 to 100 km/h (0 to 62 mph) in less than 10 s through e-mobility.

The mind-set for such a driving pattern, battery sizing, electric motor design, thermal management, weight management, and electronics has to be different. With this backdrop, it now becomes a simpler problem statement for OEMs and their vendor partners to "design e-mobility with a frugal and pragmatic mindset."

With innovation embedded in many Indian organizations, and the use of technology for virtual development and product engineering, the time-to-market has of course reduced significantly. The tools being used to conduct simulations for matching components and deriving the synergy through virtual development may not warrant the very high-end versions of equipment and instrumentation.

Over time, the growing maturity in business practices to tie in the holistic approach with customer-centric development has led to the launch of many e-mobility prototype products and small-volume launches. The multiple soft and hard levers to network the kind of investment in technology and the deployment of these innovations are yet to scale up in the Indian ecosphere. The belief in e-mobility by the consumer and the ecosphere has to be geared up by OEMs, infrastructure, government, energy providers, regulations, and policies.

E-mobility by Indian OEMs has been deployed in some overseas markets and in India to different levels. Some of them have taken the above aspects in consideration while designing and developing these vehicles. Few Indian OEMs have two-, three-, and four-wheelers in pilot markets and small niche volumes.



The next-generation Reva NXG.

The extent of success and penetration is still an issue. This is because of the overall cost of the vehicle, in particular the cost (and weight) of batteries; the lower credibility of battery management systems; the pairing of traction motor electronics for applications; charging infrastructure for batteries; driving range offered; post-sales experience; the skill set availability for development, manufacturing, and after-sales service; regulatory policies in place; and the recyclability of the components.

Charging infrastructure for battery systems is an area of opportunity that requires a deep-dive study before large investments are made to build the pan-India canvas. Regulatory frameworks in public and private industries to have employees pay for the electricity being used for charging their e-vehicles in the offices is yet to be worked out. To overcome these challenges, different business models have been developed and deployed by OEMs, venture capitalists, and enthusiasts through governmental support and broad-brush actions as in different parts of the world.

Open-source platforms to share development scenarios, ideas, challenges, and opportunities that are faced by mobility engineers are important. E-mobility has to be viewed holistically, starting with propulsion involving multiple motor technologies, power electronics, control architectures, alternate materials, vehicle handling and dynamics, communication networks and controls, recycling and end-of-life of vehicles, ideation, processes, techniques for virtual engineering, mass-transport solutions and smart networking, and policy decisions.

Innovation in e-mobility begins at the ideation stage when the styling of a vehicle commences, as engineers and marketing teams are jointly capturing voice of customer, and at the convergence with manufacturing engineers, infrastructure, and vendors to establish economic viability of a new vehicle platform. Many gizmos in e-mobility may not be needed; however, efficient energy management is an imperative with an 'energy walk' for optimizing the cost.

Innovation and sustainable product solutions are acclaimed DNA of many stakeholders, but how much of it is actually being fostered and how many of these e-mobility products are in the mass marketplace? The challenge of innovation and incubation for e-mobility for mass-market deployment has to be better channelized commercially in India.

Innovation has to be intrinsic to the vehicle and in engagement with the ecosphere through customers via intelligent transport solutions, vehicle-to-vehicle handshaking, and smart infrastructure. It has to leverage the technologies to horizontally deploy the advantage for cost optimization and customer aspirations.

The economics of putting together such a model in an evolving infrastructure and dynamic emerging market, where there are more players on the canvas now, is a commercial uphill task. In addition, the mind-set of the current talent pool and lack of the right talent to engage in development, combined with the need for speed and to do more with less, is a perennial challenge. An underlying aspect during strategizing is to understand that it is a matter of time before Indian consumers will also scan eco-labels the same way that they interpret nutrition labels today.

The Prime Minister of India in January 2013 unveiled the National Mission on Electric Mobility (NMEM) and formed a **National Board of Electric Mobility (NBEM)** to create a fast track pathway for e-mobility for the Indian ecosphere. This board has created different subgroups to manage and integrate various aspects of e-mobility in the Indian context for ideation and growth of technological development, infrastructure, components and systems, regulations and policies, any incentives, and skill-set training for talent pipeline. This mission is an industry-government partnership to take e-mobility to the next level by providing necessary levers for smart solutions that can be deployed across Indian borders.

In the Indian ecosphere through NMEM, e-mobility will provide a holistic opportunity where the auto manufacturers, consumers, energy providers, urban planners, academia and research labs, health care agencies, policy makers, and government to partner and implement together. This holistic business model canvas must have the respective modules to fit into the vision and mission of sustainable e-mobility deployment. To make this a successful business model, it will be nurtured, monitored, resourced, and deployed in unison.

Currently in some parts of the world, the challenge of e-mobility deployment has been passed on to the auto manufacturer and the acceptance of the product to the consumer. This creates a huge gap and challenge on the cost front and sustainability of the technology solution.

In the Indian ecosystem, the vendor base to work with the auto manufacturer is at a loss due to lack of visibility and volumes. The developers of the major systems are unable to find solutions that work in unison since there are no common platforms that integrate and provide a direction. The skill-set base is lacking and the socio-economic environment does not encourage the fraternity to pursue options in e-mobility as a career due to factors mentioned above.

To succeed at this balancing act, we have to proactively engage in holistically synergizing innovation and technology lest the tsunami of change takes us by surprise. To arrive at the tipping point, it is important to develop the major systems through a collaborative effort, total commitment, vendor participation, and bring in global perspectives for incorporation in strategies to ensure that e-mobility delights the consumer. ■

Building cars from Legos

"The cheapest part is the part you don't need," said CMF-A chief Gérard Detourbet in India. (Reuters)

The new Renault-Nissan plant for low-cost Datsun cars in Chennai provides an opportunity to explore a tale of two modular system approaches.

by Bertel Schmitt

In hot Oragadam in India, and in Wolfsburg, Germany, engineers and executives have bet the future of their companies on something little boys already do routinely. They build cars out of **Lego** kits. Both at **Volkswagen** and at **Renault/Nissan**, the bet is that these kits will help propel unit sales beyond the 10 million mark. This is where the similarities end.

Students and faculty at engineering schools in Japan used to call it the "Lego principle." Break down a car into modular building blocks, and revolutionize the way cars are developed and built. Develop once, run anywhere.

Building cars is not quite child's play yet, but several large OEMs are working their way toward that elusive ideal. The company that springs to mind when thinking about cars from kits is Volkswagen, while the Renault-Nissan Alliance rarely finds itself at the top of the cars-from-kits awareness scale.

Engineers in Wolfsburg all seem to age prematurely. White hair belongs on the head of a senior Volkswagen engineer/executive like the VW logo on their building. The charismatic and outspoken Gérard Detourbet, on the other hand, looks much younger than his PR head-

shot, and he definitely does not look his 67 years as we meet in a thankfully well air-conditioned **Hyatt** in an otherwise sweltering Chennai, India.

Detourbet greets the challenge of his lifetime in India, and it invigorates him. Brought back from retirement, the former program director of Renault's MO platform arrived in India in January 2012 to fulfill a dream. Other engineers may dream of supercars; Detourbet dreamed of "building a smaller car, smaller than the smallest car we have in the Alliance. In my mind, I started working on it four years ago."

In reality, work started in spring last year. The car will be launched in 2015. Detourbet, his boss Carlos Ghosn, and with him the whole Renault-Nissan Alliance hope it will succeed where **Tata's Nano** failed, that it will finally set off India's mass motorization. The hopes are pinned on an ultra-low-cost car, sold under Nissan's revitalized **Datsun** logo.

"It won't be a car on a 25-year-old platform that was amortized several times already," Ghosn promised in Chennai. "It will be totally modern, totally new. It won't be localized, it will be local, designed and built in India."

Ghosn won't say more than that the price of the car will be "not far from the entry competitor." India's car-crazy media did the math and arrived at around \$3680, converted from 240,000 rapidly depreciating rupees.

Common Modular Family

How can you hit such a price point and still make money? By using Renault/Nissan's new Common Modular Family (CMF) architecture. And by putting Detourbet in charge of the project. Underpinning the **Dacia** line, Detourbet's MO platform helped save Renault's bacon in an im-

ploding European market and elsewhere.

Under the CMF architecture, the car is divided into five modules, explains Renault's Engineering Chief, Jean-Michel Billig, in Paris: "Engine compartment, front underbody, rear underbody, cockpit, and the electronic architecture, each with between one and three big modules to choose from."

After getting to work in earnest in March 2012, Detourbet and his small team of engineers, working out of the Alliance's tech center near Chennai, not only developed a completely new car in a time "it normally takes to do a derivative" as Detourbet mentioned. While they were at it, they also developed the complete modular architecture the new car will be based on.

CMF is split into three families. CMF-A, developed by Detourbet, is the basis for the Alliance's entry level and sub-mini models. CMF-B will be for cars the size of a Renault Clio. CMF-C/D will buttress vehicles the size of the Nissan Rogue, Qashqai, and X-Trail, or Renault Espace, Scénic, and Laguna. The first CMF-C/D Nissans will appear by the end of 2013, with the Renaults to follow a year later. CMF-A will hit the Indian market in 2015. A first prototype should appear at the Delhi motorshow in Spring 2014. CMF-B based units will appear "at a later date," as I heard in Yokohama.

"The best way to reduce the cost of a car is to reduce the number of its parts," said Detourbet. "You get a car that costs less to engineer, it is easier to assemble, and it has less to go wrong." A lot of Detourbet's time is spent chasing down unnecessary complexity. Where other air conditioners have a multitude of knobs and buttons, Detourbet's A/C only has one knob. Detourbet uses the same rear-view mirror on the left and the right. "Engineers create a lot of things that are never used by the customer, they don't make cars for the customer; they make cars for themselves. The secret is to make what is expected, by the customer, and not more."

Countering blandness

Like many revolutions, modular architectures can meet resistance among the establishment. The most common counterpoints are that modules lead to even blander cars, fed from a common parts bin, and that if something goes wrong, it will be the mother of all recalls.

In Paris, Billig "strongly denies" the notion of increasing boredom. "CMF standardizes all that is not visible, which allows us to put money and investment into what is visible. An



"It won't be a car on a 25-year-old platform that was amortized several times already," said Renault/Nissan CEO Carlos Ghosn at the tech center near Chennai, India.

underbody adds nothing to the brand, so let's standardize it and take the money to make more attractive and more seductive cars."

Ulrich Hackenberg, the Board Member for Technical Development at Audi AG and all other VW Group brands, says the concept leads to better quality. Instead of making 130 different versions of the same engine, there is only one version, which will be tested again and again in each new car that uses it. "I don't think there is any car maker in the world that does such intensive testing of its components [as VW]," Hackenberg claimed.

Detractors like to say that "modules are just another word for platform." Semantics indeed play a big role in the modular business, and this is where the Renault-Nissan Alliance needs help.

"CMF is not a platform," espoused a Nissan press release this summer. "A platform is a horizontal segmentation; a CMF is a cross-sector



Building cars from Legos



“Other companies may be working on these systems, but they don’t have enough brands to effectively make use of them,” said Volkswagen R&D Chief Ulrich Hackenberg.



“An underbody adds nothing to the brand,” said Renault Engineering Chief Jean-Michel Billig.

concept.” The release did not reach Nissan’s CEO Carlos Ghosn. He happily called CMF-A “a platform,” a discrepancy promptly noted by an irritated Indian media. The 67-year-old Detourbet also does not want to switch to the new nomenclature, and insists on calling his brainchild “a modular platform.”

There is no such Gallic verbal laxness in Wolfsburg. Here, the matter is firmly in the hands of Teutonic terminology. Volkswagen spokesman Christian Buhlmann gives a 90-min presentation about the true doctrine of MQB. Fortified by 78 PowerPoint charts, Buhlmann has given the talk “so often that I could give it in my sleep,” as he says.

According to Buhlmann, Volkswagen “changed from a platform approach to a modular strategy when Professor Piech was still CEO,” i.e. in the 1990s. In Volkswagen’s belief system, platforms went out with the advent of PQ35, which it calls a modular system. That modular system is now likewise being sent to pasture, displaced by Volkswagen’s “Baukasten” or “assembly kit” architecture. Volkswagen is a whole generation ahead of the competition—at least as far as semantics go.

Dramatic development cost reductions

In the low-cost-car department, on the other hand, Volkswagen is not bursting with urgency. “We are working on a low-cost car,”

Hackenberg disclosed. “We are at the beginning, in the design phase, but we know what we have to do.”

Deservedly or not, Volkswagen has turned into the benchmark of modularization. To the delight of VW’s Investor Relations, MQB has become the topic of many research notes, where analysts escape the tedium of EBITA to venture into the exciting world of parts numbers. The professional should read the research with caution.

A recent **Morgan Stanley** note crowned Volkswagen as king of the modular realm, followed by **Toyota**—never mind that little or nothing is known about Toyota’s New Global Architecture (TNGA), except that the first new TNGA cars should appear by 2015. If you are really friendly with Toyota’s Tokyo spokesfolk, you may hear that “even we don’t know what TNGA is all about.” Which most likely is true.

A widely circulated note by **Bernstein Research** set out to debunk Volkswagen’s claim that, with MQB, its cars will cost 20% less to produce—never mind that Volkswagen never claimed this. Sure, savings between 20 and 30% have been mentioned both by Volkswagen and Nissan. Even Toyota, while saying little or nothing about its modular system, mentioned savings in the same neighborhood. The question is: 20% of what? Of R&D? Very doable. Of parts purchases? Achievable. Of the whole car? Probably not.

“As far as development costs are concerned, the reductions can be dramatic, 20 to 25% for sure,” said Billig, and he continued that “by buying a million instead of 300,000 parts, purchasing should be able to make big savings.” The exact number Billig refuses to know, claiming that he is “not in purchasing.”

Modular the way to go

The back-of-the-envelope number is that the development of a new car costs a billion dollars, “or rather a billion Euro,” as Buhlmann interjected in Wolfsburg. A modular system could shave off 200 to 300 million from that number, dollars or euros. A rule from the back of the same



“The CMF concept does not require additional changes in the production process,” said Tsuyoshi Yamaguchi, Renault-Nissan Alliance Director responsible for engineering.

envelope says that 60% of the cost of a car is in the plant, 20% in parts, and 20% labor. Both Billig in Paris, and his Yokohama-based colleague Tsuyoshi Yamaguchi, Alliance Director responsible for engineering, say that a modular system does not change that equation in a material way, hinting at a possible weakness of the Volkswagen approach.

With the factory the biggest line item, you want to keep an eye on it. MQB and its three-letter brethren at Volkswagen require a completely and expensively re-engineered plant. Multiply this by 26 plants in Volkswagen’s worldwide empire. Nissan’s Chennai plant does not look like anything special, and Yamaguchi cheerily concedes that point: “The CMF concept does not require additional changes in the production process.”

Criticized by analysts, Volkswagen stopped naming numbers. Buhlmann asked reporters not to mention any money when they are about to interview the R&D Chief. Hackenberg studiously avoids the topic. He does not venture any closer to the hot potato than mentioning that parts runs can now “go up to six million a year,” and he leaves the rest as an exercise to the student.

As much as Renault/Nissan’s big modules and Volkswagen’s kit approach may differ, all agree that there is no future without these systems. “For us, there is no other option than



The CMF architecture divides the car into five modules.



No costly re-engineering needed for the new Datsun at the Renault-Nissan plant in Chennai, India.

being successful with the CMF strategy,” said Renault’s Billig in Paris. In Yokohama, his colleague Yamaguchi-san sees car makers without a modular system “at a huge disadvantage. Even if they have scale, they cannot enjoy it.” In Wolfsburg, Hackenberg says that “other companies may be working on these systems, but they don’t have that variety of brands to effectively make use of it.”

In Tokyo, Toyota’s Executive Vice President, Mitsuhsa Kato, lifts the kimono of silence a little and says that “considering the ever intensifying competition among global OEMs, the time is now requiring us to develop more-attractive products and to do so in a smarter and more efficient way than ever before. This is what TNGA is all about.” ■



Mobility in 21st-century India

A common daily scene of traffic in national capital Delhi.

India's rapidly growing population has made transportation systems unable to effectively keep up with demand, losing the country untold man hours and wasting money.

Transportation has become life force in this century. Cities couldn't exist without transportation forms. It would be a rare day when you would not use some form of transportation. Transportation has been a leading step in development, emerging economies, and improving quality of human life. But is current transportation system development moving in the right direction? Developing nations such as India, China, and Brazil are current targets for automotive manufacturers. But do existing infrastructure and transportation systems have the capacity to support their ever-increasing population? Can increasing fuel prices, heavy imports, and increasing fuel consumption support the economic condition of these countries? Could developing roads and increasing the amount of passenger cars solve the problem?

India's automotive growth

The Indian transportation industry is one of the largest, most diverse, and least planned transport sectors in world. It fulfills the needs of 1.24 billion people. From 2011-12 the transport sector contributed 6.8% to the nation's GDP in which road transport has the lion's share with 5.5% to GDP with a targeted growth of 10% per year.

The 21st century brought rapid growth to India; the passenger car industry has benefited most in the transportation sector. As of 2010, India is home to 40 million passenger vehicles. More than 3.7 million vehicles were produced in India in 2010, making India the second fastest growing automobile market in the world. According to the **Society of Indian Automobile Manufacturers**, annual vehicle sales are projected to increase to 5 million per year by 2015 and more than 9 million per year by 2020. By 2050, the country is expected to top 611 million vehicles on the nation's roads.

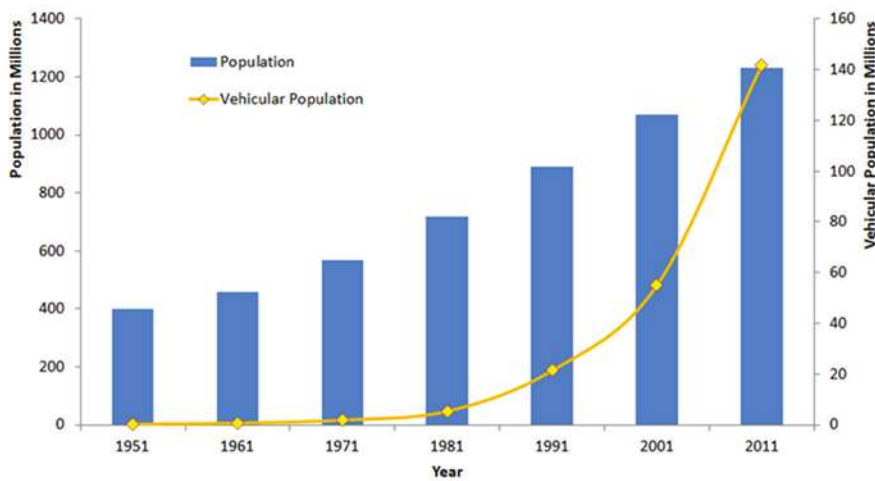

This graph is showing growth in population and vehicular population from 1951 to 2011. Rapid growth is seen after 1983, when Maruti started its production and after 1991 when international OEMs started to appear in the Indian market.

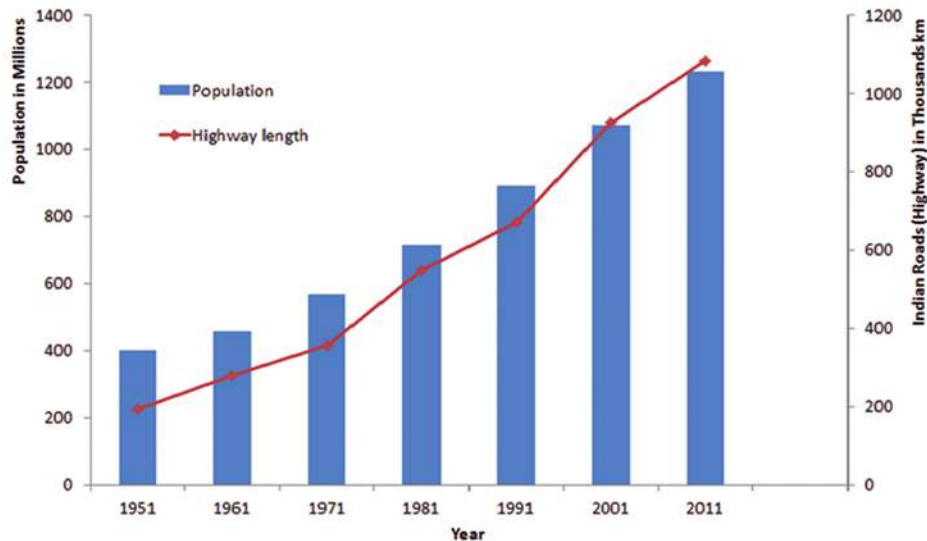

This graph is showing growth in population with road network development from 1951 to 2011.

Conversely, in economic terms, this ever-burgeoning vehicular population has created problems with the economy due to high import of fuel and the depreciating Indian currency value. The Indian government is facing a very tough situation to control oil consumption to reduce import to come out of the current economic crisis. In terms of passenger comfort, the increasing number of vehicles is outpacing any such measure of road network development. Although the density of India's highway network is (0.66/km² of land) similar to United States (0.65) and much ahead of China (0.16) and Brazil (0.20), most highways are narrow, have poor surface quality, and do not have maintenance services. Traffic congestion and unplanned development jeopardize growth of business, extreme pollution of environment, and wastes money.

Delhi commuting

For a Delhi city commuter, long lanes of unending traffic during crucial hours of the day wasting time and money in congestion is very common. Add seasonal rains to this and a commuter's traffic woes increase. In 1990, there were 1.9 million vehicles in Delhi. By 2010 that number rose to 6.6 million (an increase of

250%). During the same period, Delhi's population has increased by only 76% (from 9.5 million to 16.75 million) and road-length by merely 50% (from 22,000 to 33,198 km).

The situation is similar across a number of cities in India and the developing world. According to a survey, \$30 trillion will be spent on transportation infrastructure in the next 20 years worldwide. As a developing nation, India is investing heavily in public transport to serve the needs of increasing population and to support development.

But increasing infrastructure and road development does not seem to be a solution for these problems. Maintenance costs of existing road, rail, and air systems are very high. The new model should be planned by increasing the capacity of existing systems by predicting demand and moving toward greener technology without compromising safety. These goals can be attained only by strong political will, transparent government, and participation of a private-public model with accurate prediction.

At policy level, a central government land bill should be used that gives priority to minimize the needs for transport and increasing percentage of trips made by environmentally cleaner modes with full compliance of 2005 **World Health Organization** air quality guidelines. The Indian government should pace for regulating vehicles load and implementing environmental regulation with Bharat stage five.

Public transport improvement needed

To improve quality of life and to provide hassle-free movement, public transportation should be dominating, particularly in big cities for intra-city travel. In this area, government has taken a good step in the form of the **Delhi Metro Rail Cooperation** and other metro rail projects. In the words of a customer: "Prior to the Delhi Metro, the capital city suffered from lack of an adequate, reliable, and safe public transport system. The metro is the first effective solution to the city's

Mobility in 21st-century India

Indian Car Market 2012



2.654.835 units
Record year

+9,1%

World's
6th
largest
car market
between
Russia and
the UK

BRIC
Growth:
better than
China and Brazil.
Worse than
Russia

New Car reg/
1000 inhab:
INDIA: 2,1
China: 10,8
Russia: 20,4
Brazil: 18,6

Indian car market comparison to other developing countries.

transport problems—catering to all classes of people with an affordable and practical solution.” Moreover, the Delhi Metro is the world’s first railway project to be registered by the **United Nations** Framework Convention on Climate Change under the Clean Development Mechanism. It has claimed carbon credits, amounting to 12 million rupees annually, for the use of a regenerative braking system.

But comfort, reliability, and safety of the metro, and parking conditions at metro stations are getting worse by the day due to an exponentially increasing population. The number of passengers on the Delhi metro has greatly increased since its launch—from a mere 20,000 commuters per day at its outset to 2.2 million per day in 2013, and that number is expected to double by the end of 2020. Development of a mass rapid transport system has not kept pace with an increasing population resulting in a lesser share of total passenger travel and an overcrowded system.

For smarter transportation, the government should work toward increasing the proportion of passenger travel by public transport. This can be done only by increasing comfort, safety, reliability, and availability to the public.

Potential of Indian railroad systems and aviation

In terms of intercity connectivity, Indian railroads could have played a major role. Railroads in India have become the victim of Indian politics. Trains have a history of never arriving on time, which wastes money and man hours each year. An independent survey reports it was shown that delayed trains cost around 2.5 billion rupees to railways in the past year. During cold weather and in fog conditions around one half of passengers suffer delays in their plans. For the past 10 years, average travel by Indian railways has nearly doubled (from a total of 51 billion km in 2002 to 97 billion in 2011). However, railroad tracks increased by only 2% (from 63,122 to 64,460 km). During the same period of time, Indian railways did not lack funds as earnings nearly doubled (30 billion to 50.5 billion). They lack political will and implementation. In comparison to other modes, the aviation industry has done far better work, which is reflected in pacing growth of 410% the distance traveled in the past 10 years. But still penetration to middle-size cities and infrastructure is not available, making it impossible to be an option of road transport. Cost of transportation also plays a very important role as travel by air is highly costly in comparison to other modes.



Looking to the future

India has two options: it either accepts increasing car use and tries to provide the necessary infrastructure or it can control car use to keep it in bounds defined by broader social objectives. But in doing so it would have to support a substantial improvement in the quality and scale of public transport. India should encourage traffic calming and traveling by foot, use advanced smart traffic management systems to increase operational efficiency of the existing network. By increasing public transport, India could achieve growth in the economy by reducing the import of oil, savings in vehicle operating cost, reduction in pollution, and congestion. ■

Vibhor Jajoo

Vibhor Jajoo graduated from Indian Institute of Technology, Varanasi, in 2013. He is interested in sustainable development of transportation system in India. He can be visited at www.jajooibhor.co.nr.



ACTIVE SAFETY. PASSIVE SAFETY. LEARN THE LATEST IN THIS CONCISE NEW BOOK

Integrated Automotive Safety Handbook

By Ulrich W. Seiffert and Mark Gonter

Written by two of the foremost automotive engineering safety experts, this book takes a unique and comprehensive approach to describing all areas of vehicle safety and provides a solutions-based perspective of integrated vehicle safety. Chapters include:

- Accident research
- Functions of integrated safety
- Biomechanics and protection criteria
- Injury mitigation
- Adaptive occupant protection, compatibility, calculation and simulation

SAE Member Price: \$87.96*

List Price: \$109.95

Product Code: R-407

ISBN: 978-0-7680-6437-7

Published: August 2013

*Discount based on Elite Member level.
For more information on member levels, visit
www.sae.org/membership/benefits

Available in print, eBook and enterprise multi-user access.

Order today! Visit books.sae.org/book-r-407

Email: CustomerService@sae.org

Actual shipping charges will be applied

Low-cost instrument clusters



A Delphi expert proposes a design strategy to help overcome challenges for manufacturability of automotive displays suited for emerging markets.

In emerging markets such as India, a major challenge for interior suppliers is to strike a balance between the low-cost product requirements and DFM considerations. (Tata Motors)

All electronic control units (ECUs), once designed and validated, obviously are required to be manufactured. Automotive display products—instrument panel clusters (IPCs), infotainment, etc.—are no exception. Their architecture and design must ensure that they can be easily (i.e., low effort), efficiently (i.e., cost-effectively), and robustly (i.e., error-proof) produced on the assembly line. Design for manufacturability (DFM), therefore, is a critical design factor.

Sufficient support in the ECU product design needs to be incorporated early in the product life cycle for the product to be successfully and efficiently manufactured, necessitating serial communication capability in the design. However, in low-cost automotive instrument clusters the customer requirements for the product typically do not encapsulate serial communication, and the ECU is not required to support repair/rework out of field rejection.

Delphi's ECU manufacturing plant has main and final assembly lines with various subassembly processes.

According to the common process for manufacturing competency, at every key stage such as in-circuit test (ICT), functional test, pointer staking, calibration, and final functional test, the test engineer/technician needs to access the IPC's resources. These include:

- Memory, for read/write operations of that particular stage's result (pass/

fail) and keying-in part identification such as part numbers, sequence number, etc. These eventually need to be recorded in the factory information system (FIS) for further traceability.

- Control, for executing the IPC's feature override and reading data via IPC's interface to the vehicle connector.

India is an emerging and fast-growing automotive market. Having a majority of cost-conscious end customers, OEMs are continuously pushing for cost-effective IPC designs in their vehicle platforms, where the key is maximum feature/functions at minimum cost. Delphi, therefore, is constantly challenged by the requirements of its customers in this regard. A main challenge is to strike a balance between the low-cost product requirements and DFM considerations.

Technical challenges for low-cost IPC manufacturing

Of the various challenges faced in low-cost IPC manufacturability, a critical one is the communication with the product at the main and final assembly lines. A key consideration of DFM for IPC products is the serial communication capability for the tester to access product memory and controls. It is this feature that often gets omitted by OEMs in their technical specification of low-cost IPCs, as the intent for such ECUs, even at their vehicle assembly line and service station, would be to do away with any kind of additional product interface for economic reasons. The choice made instead is part replacement as a whole ("pitch").

An automotive use-case (IPC1) of an ECU design that is low-cost and faced with the above challenge is useful. For this case, the product's mechanical design is without the back cover component; instead, a thin layer of Mylar sheet (for electrostatic discharge protection) is used.

The IPC1's access during assembly is made convenient due to the accessibility of the necessary pins and test points on the rear-side of the printed circuit board assembly (PCBA). For

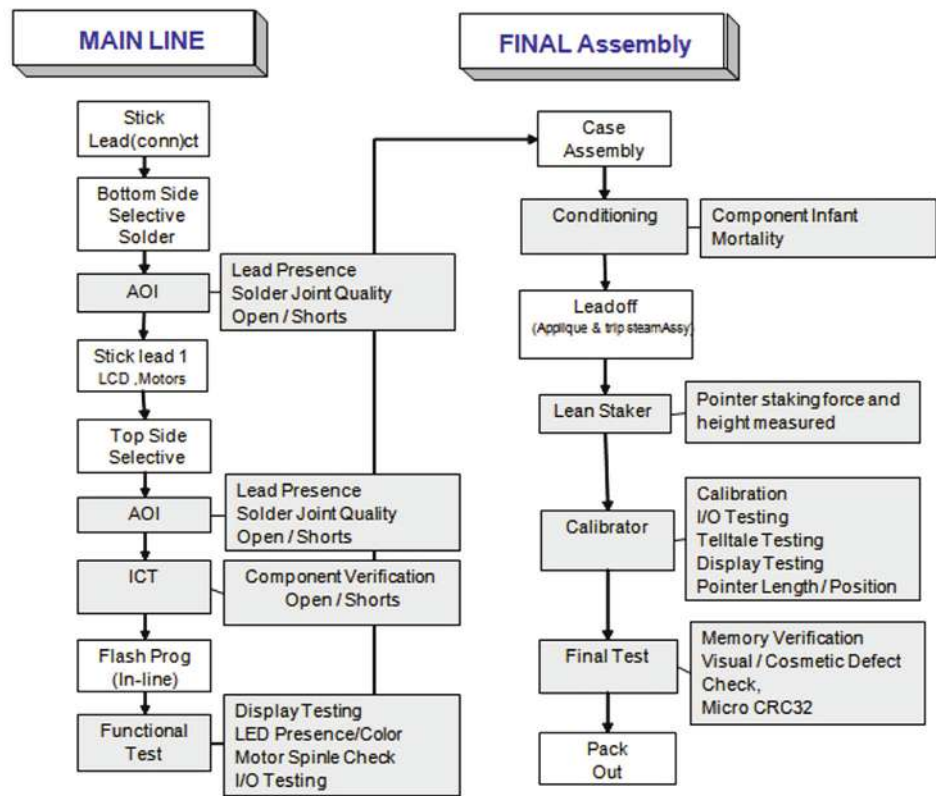

Subassembly processes for the main and final assembly lines.

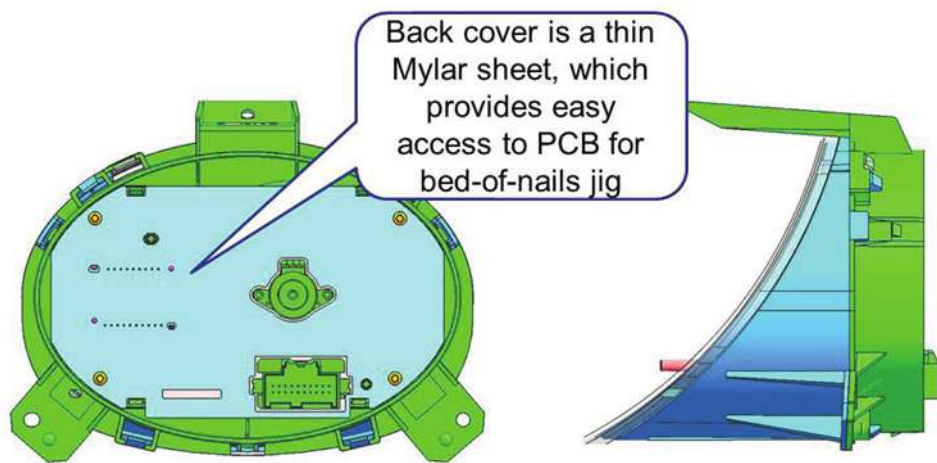

IPC1 use-case back cover design.

instance, flashing (or re-flashing, in case of rework on the product) is done with the design of a suitable bed-of-nails jig arranged in the fixtures facilitated with an instrumentation interface. Hence, the challenge was addressed.

The design of IPCs with or without the back cover is a decision usually made by the OEM at design conception, thereby seldom offering flexibility as in the IPC1's case. Moreover, while it is a cost advantage to eliminate the back cover in the design, standard design and validation guidelines highly recommend having a back cover due to the following rationales:

Low-cost instrument clusters

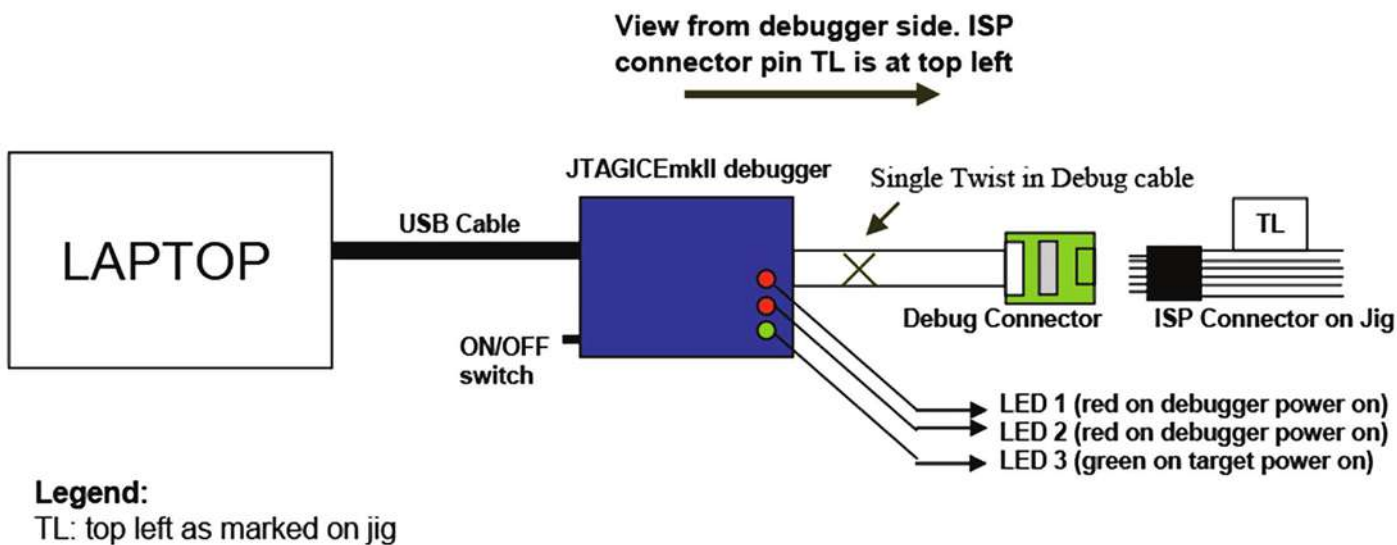

IPC1 re-flashing setup.

- Adequate protection of the PCBA and connector against electrostatic discharge
- Protection of the ECU from environmental conditions such as humidity, water ingress, dust ingress, and heat dissipation
- A must in case of snap design assembly, which is the de facto standard for all current automotive IPCs
- A must in case of dual-sided PCBA designs.

Design considerations

The following methods can be considered, or have already been designed, for addressing this challenge. However, a single method may not completely eliminate all the repercussions associated with the issue without involving design and complex implementation, something that automotive embedded designers may not consider worthwhile.

Cavity in the back cover: The idea is to provide a suitable cavity in the back cover or the retainer for manufacturing test setup to access the necessary test points on the PCBA. However, the outer dimensions being OEM's packaging, fitment, and aesthetic concerns, this can take some hard bargaining with the OEM to achieve. Yet, the downside is that one has to face some of the aforementioned challenges due to the exposure of a portion of the PCBA to ambient conditions in the vehicle.

Process adjustments: This method involves making suitable adjustments in the manufacturing or assembly process stages such that at whichever station there is a need to access the test points on the PCBA, jigs are designed and maintained in the fixtures, and the back cover or retainer assembly (as the case may be) is not assembled yet. But this method—besides adding expense in terms of multiple fixtures—poses challenges to the conventional manufacturing design, specifically at the “marriage station.” In the IPCs with snap-fit design, this is where the PCBA is sandwiched between mid-housing and back cover for efficient handling of the part in further stations such as pointer staker, calibrator, and final functional test.

Private serial communication: The best of the techniques is to design the IPC to provide a private serial communication link in the hardware and have the product software implement the necessary protocol stack. Of the various standard serial communication links such as CAN, LIN, and KW2000, the latter is perhaps a simpler, cost-effective, and easily implementable method and offers the same convenience in the manufacturing line.

IPC design for manufacturability

Consider low-cost IPC designs that do not have customer requirements on any serial communication support, and hence are faced with the challenge of manufacturability. Selecting the “private serial communication” technique, the design decision that can be made is to have provision for KW2000 communication support on UART (universal asynchronous receive transmit) pins of the microcontroller employed. The UART port's Tx and Rx pins from the microcontroller are routed onto two of the product connector pins that are “Not Connect” with suitable protection electrically.

The selection of product connector pins is critical. This strategy must be with consent from the customer, for the assignment of pins comes from their requirement. This method may be employed only if there are at least two free (“Not Connect”) pins on the connector(s) and will not be used for future expansion by the customer. Having more free pins is recommended so that the UART pin assignment can be moved around depending on future requirements.

The KW2000 serial communication works on the UART link, but it requires a transceiver (and possibly a level shifter to convert from computer's serial port voltage levels to 5-V level, a KW2000 physical layer

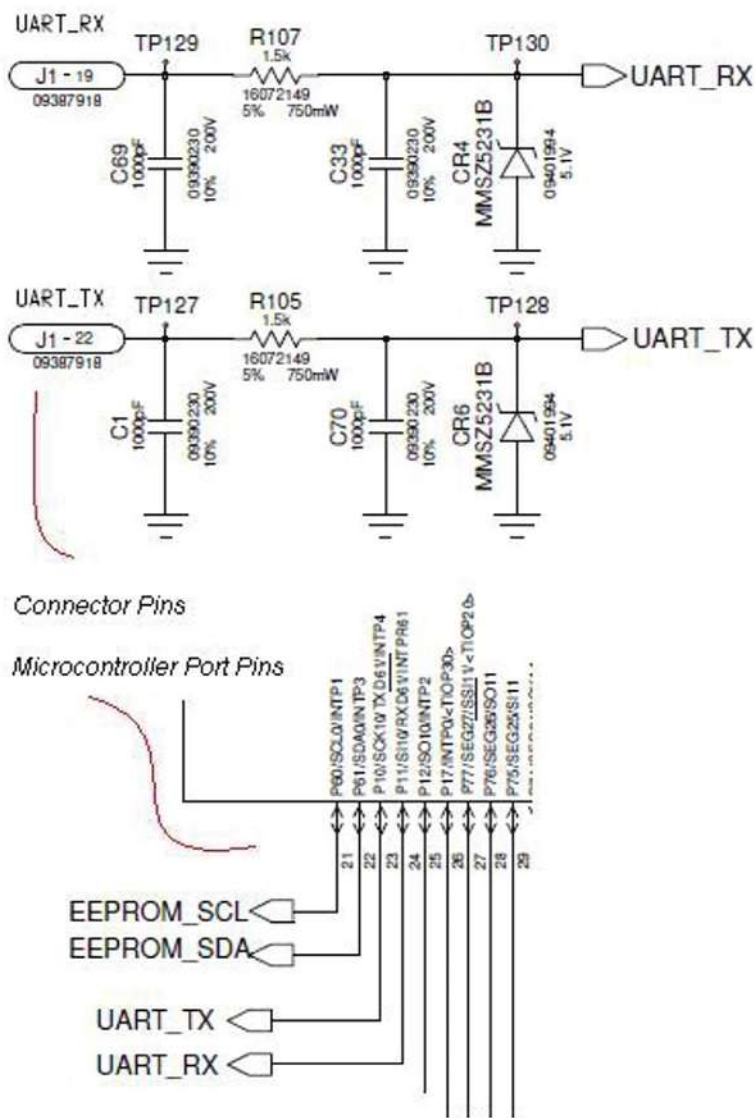

Product schematic showing UART connections.

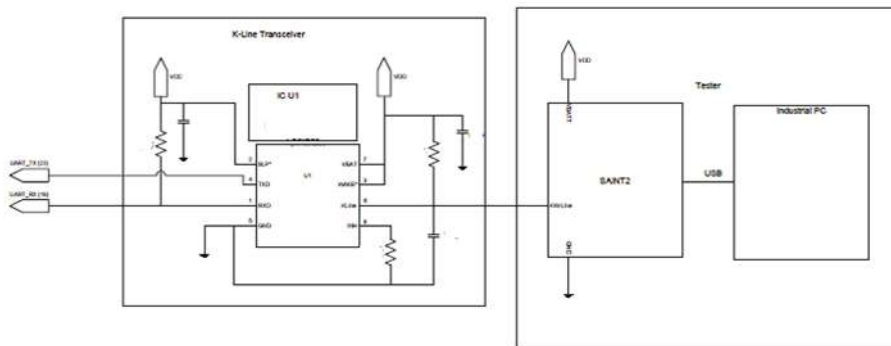

IPC serial communication interface setup at the manufacturing line.

requirement). This design strives to be cost-effective by ensuring minimal bill-of-materials addition. Therefore, only the minimal interface is designed on the PCBA while in the manufacturing test fixture the KW2000 transceiver chip and the necessary tool (such as Saint2) for communicating on this protocol are installed. Such a simple setup is sufficient to access the IPC internal details at

desired stations in the manufacturing plant.

Since KW2000 is a single-line communication, while the microcontroller interface has two-wire UART, whatever command or message is transmitted between the IPC and the tester is received back. A minor adjustment that the standard KW2000 tester needs to make is to ignore the echo.

With the hardware provision designed, the software support needs to be implemented. Since it is a private communication protocol, one is at liberty to choose any custom protocol stack. An input trigger could also be implemented (for instance, a combination of mutually exclusive hardwired inputs to the product) to ensure safe entry and exit for manufacturing mode in the IPC, such that in the vehicle there is no serial communication triggered inadvertently.

The advantage of this strategy is that it's a full-fledged diagnostics protocol and the manufacturability support is mostly diagnostics services, thereby providing significant reusability of the software building block. Additionally, since serial communication ensures faster and automated access at the manufacturing line, a cycle time advantage is also evident. Moreover, providing serial-communication capability offers design flexibility; for instance, in designing for dual-sided reflow process of the PCBA.

DFM being a critical design consideration and low-cost IPC design presenting a unique set of challenges, an efficient solution is warranted from designers. But the challenges can be addressed in a safe, cost-effective, and convenient way and still ensure customer requirements for the product are not compromised. ■

This feature is based on SAE International technical paper 2013-01-1232 written by Sreedhar Thanthy, Systems Engineer for DDS Electronics at Delphi Technical Centre, Gillingham, U.K. The paper was part of the "Automobile Electronics Design and Systems Reliability" technical session at the SAE 2013 World Congress in Detroit.

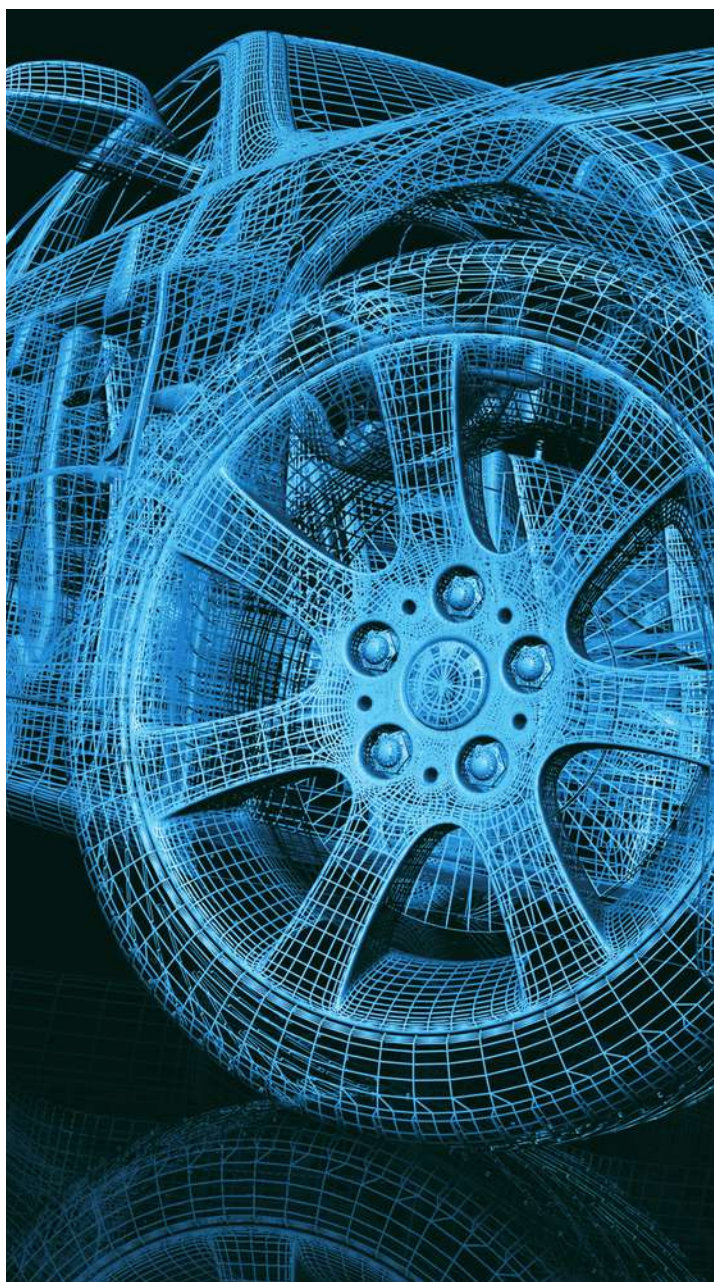

FREE 2013 GLOBAL POWERTRAIN VIRTUAL SUMMIT

Thursday, December 12, 2013
8:00 a.m. - 5:00 p.m. U.S. EST
www.sae.org/events/globvirt/

A free online event that provides the opportunity for you to explore global advancements in powertrain technology – from the comfort of your home or office.

Attend and Submit Questions to Panelists at Three Thought-Provoking “Theater Webcast Presentations”

Feature Webcast Presentations

- **Designing Off-Highway Drivetrains to Meet End-User Demands** (9:30 a.m. – 10:30 a.m. U.S. EST)
- **Vehicle Onboard Fuel Additive Systems: Exploring Their Role and Value** (Noon – 1 p.m. U.S. EST)
- **The Path to Improved Fuel Economy** (2:30 p.m. – 3:30 p.m. U.S. EST)

Register NOW to:

- Gather real-world advice by chatting with industry experts
- Learn about powertrains emerging technologies, trends and issues
- Visit the virtual “Resource Download Center” for valuable information including the latest white papers, demos, podcasts, product information, and technical presentations
- Network in the “Networking Lounge” with like-minded professional for both group and private chats
- Enter to win prizes by visiting exhibitor booths in the virtual “Exhibit Hall”

SAE International Contact:

Megan McCoy
e: mmccoy@sae.org

For 2013, the scope of this free global event is expanded as the Global Powertrain Virtual Summit. This year’s Summit not only examines the global advancements in powertrain and engine technology for the ground mobility industry but also addresses regional issues, benefits, and advantages on a global scale.

Summit Host
Lubrizol

Content Reviewed
and Facilitated by

SAE
INTERNATIONAL™





METALS MAKE A COMEBACK

The Boeing 777 assembly line in Seattle shows plenty of evidence of conventional metal structural components dominating the scene. (Richard Gardner)

A look at how new metallic and hybrid materials are competing with carbon composites for a continuing role in aerospace manufacturing.

by Richard Gardner

The past two decades in the aerospace sector have seen a steady trend toward the increasing use of CFRP (carbon-fiber-reinforced plastic) composite materials beyond weight-saving components for aircraft into major primary structures on a scale that was unimaginable a few years ago.

While general aviation (GA) aircraft and sport gliders represented an easy start-point in expanding the use of composites, the adoption of large CFRP structures came about in stages. Obvious items such as fuselage/wing fairings and tail assemblies provided much scope for saving weight while creating awkward aerodynamic shapes in a single piece through a relatively easy molding process, using human labor to lay-down composite sheets and requiring modest-size autoclaves.

As manufacturing experience and composite technologies improved, with more automation and investment in new manufacturing facilities allowing larger structures to be assembled, the use of CFRP components has boomed.

Moving up from adoption on GA types through business jets into regional passenger aircraft, the “plastic aircraft” soon featured as a key must-have catalog item in the product lines of the sector’s biggest manufacturers, **Airbus** and **Boeing**. This was also the case in the military aerospace sector where

new manned and unmanned airframes saw large-scale use of composites for structures.

Controversially, Boeing’s adoption of composite structural components for almost the whole of the 787’s airframe seemed to signal the beginning of the end for traditional metal structural manufacturing.

Even the giant Airbus A380 featured a huge dependency on composite fuselage and wing components. But interestingly, the latest Airbus widebody addition to its portfolio, the A350XWB, is not quite so committed to plastics and retains a mix of advanced metallic components as well as composite materials.

Another factor is also emerging.

METALS MAKE A COMEBACK



Close-up of a 787 fuselage panel showing the composite structure with metal fasteners and strengtheners. (Richard Gardner)

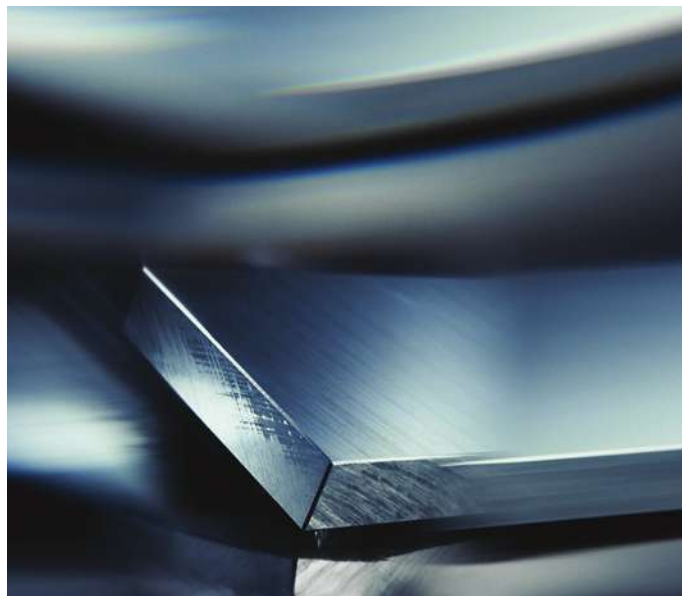

Airware from Constellium enables aircraft designers and manufacturers to meet demands for a new generation of lighter, more efficient, and greener aircraft.

Over the next 20 to 30 years, it is estimated that the world will require more than 30,000 new large commercial transport aircraft to meet expanding traffic needs as well as replacements for aging aircraft.

With production rates ramping up to reduce order backlogs and maintain reasonable delivery requirements, this increasing demand for new aircraft is likely to present a real challenge to the composite materials supply chain. This coincides with new advances in metallic materials that are re-introducing greater competition.

The latest metallic products and processes are certainly becoming far more competitive, and the signs are that they are likely to make a real comeback, especially on the emerging next-generation airframes that are shaping up on the CAD/CAM screens of the major manufacturers.

Aluminum in the air

A market leader in the supply of advanced metallic materials for the aerospace sector is **Constellium** (formerly **Alcan Engineered Products**), which has invested in a range of new Airware products tailored to meet today's demanding needs for performance (strength, stiffness, and damage tolerance), ease of manufacture, and competitive costs.

An important factor, and one seen by Constellium as an aspect that benefits from the use of metallic components, is the increasing environmental concern over the need to recycle structural materials.

Constellium provides a close focus on how waste material is recovered and reused through the supply-chain manufacturing process up to the time when the airframe is eventually dismantled after a lifetime of service use. This approach minimizes material losses and enables a positive outcome, long term, in environmental benefits.

In this respect, the advanced metallic scores higher than within the composite manufacturing and recycling supply chain, and it uses less environmentally harmful contents. Airware is 100% recyclable. These lightweight high-performance materials give overall hybrid structural solutions that offer a sustainable future, with a reduced carbon footprint.

The Airware technology features a lower density, a higher stiffness, and better damage tolerance. Combined with advanced welding and redesign of aircraft

aerostructures, the technology can provide an up to 25% reduction in structural weight, the company claims.

Higher corrosion and greater fatigue resistance increases the structural durability, and this in turn guarantees longer intervals between heavy maintenance periods out of service. These advantages are encouraging aerospace manufacturers to use advanced aluminum solutions rather than composites for more high-tech structures.

Airbus has adopted Airware structural components for the latest A350XWB (internal wing structures and fuselage), and **Bombardier** has also chosen it for the fuselage of the new 130-seat C Series super-size regional jet. Both new aircraft are due to make their first flights soon.

Airware products are available in three forms. Airware I-Gauge is the thickest low-density alloy plate (165-mm thick) and offers OEMs better performance while minimizing weight and simplifying manufacturing and the assembly of complex monolithic shapes. It is said to be 46% more corrosion-resistant and 25% more fatigue-resistant.

Airware I-Form is a highly formable product and comes in sheet form, allowing the design of complex 3-D



The F-35 is the most modern combat plane in production and uses both composite structure and metal components in the fuselage and wing. (BAE Systems)

curvature shapes with no loss of mechanical properties and a reduction in manufacturing steps. Highly formable, it is 3% lighter, 47% tougher, and 40% more corrosion-resistant and reduces the number of manufacturing steps from four to two. It is best suited for fuselage nose and tail structures—as on the Bombardier C Series.

Airware I-Core is 21% stronger and is a high-strength extruded product that comes in a low-density alloy and is optimized for a hybrid structure environment with the best crash-worthiness ratio. Its ability to absorb energy reduces the risks of structural damage in a crash or emergency landing and also makes it an ideal solution for cargo floor beams.

In March, Constellium opened a new casthouse in Issoire, France, dedicated to low-density alloys. The industrialization of the new technology has involved the reinvention of some of the manufacturing processes, with an open view on innovation. Some €52 million was spent on the new project, which included a pilot phase that took place in the company's R&D center at Voreppe, France.

Constellium is integrating its manufacturing capacity, which now comprises facilities in France, Switzerland, and the U.S. at Ravenswood, WV. These plants work closely with customers to exploit the gains that can be made from using advanced materials. A good example is the way in which the company has worked with **Lockheed Martin** on the F-35.

“To meet a critical need for very large monolithic components for the F-35, we needed to produce very large plates of previously unheard-of dimensions,” said Kyle Lorentzen, CEO of Constellium's Ravenswood facility. “This was achieved by combining a unique manufacturing capability with a tailored product range.”

On the F-35, Constellium's 7050 and 7140 alloys have been used, which offer strength, light weight, and, importantly, greater corrosion resistance. But legacy military aircraft, including the F-16 and F-18, have also received replacement materials in their bulkheads, skins, and other key structural components using Airware 2297 and 2098 alloys.

Manufacturing methods

Lithium has been in the headlines as a result of the long-running Boeing battle to cure its battery problems on the 787, but combined with aluminum, lithium can produce a range of alloys that offer the best of both worlds—the strength and lightness of CFRP materials with the more environmentally friendly ease of manufacture and flexibility of aluminum structures.



At its Issoire recycling casthouse, Constellium has demonstrated the recyclability of A300 wings and cockpit parts with a recovery yield of over 90%, resulting in new aluminum ready for use in future aircraft.

These “super alloys” are winning over many engineers and decision-makers in the main aircraft supplier companies. But the situation is subject to much change at present as the plastic vs. metal debate is very dynamic. This results from an almost continuous flow of new innovation and processes that are changing how aircraft are put together.

Many current production aircraft, such as the 787 and A380, for example, have to incorporate additional

METALS MAKE A COMEBACK

Additive manufacturing technology being developed by GKN Aerospace creates complex metallic shapes that reduce material waste, save weight, are extremely strong, and show the way forward for future exploitation in aerospace component manufacture.

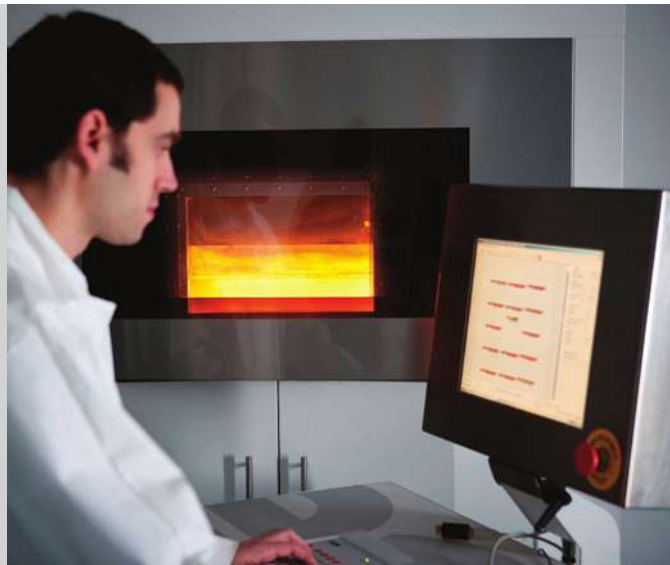

metal strengthening components, such as brackets and support struts, in addition to using very large composite panels with molded-in strengtheners.

The new-generation aluminum lithium components can be machined with great accuracy in complex forms, saving the extra complication of combining different types of structural material that adds to the assembly effort. There can be no escaping the fact that composite materials involve the use of unfriendly resins, and waste disposal is an issue. In operational terms, using advanced metallics in vulnerable parts of the structure, such as where vehicle strikes might be expected, can offer an easier permanent repair solution and better overall resilience.

Some years ago, Airbus announced at one of its Toulouse technical briefings that it was experimenting with new materials that would offer superior performance and keep weight down. This became GLARE, or Glass Laminate Aluminum Reinforced Epoxy. It turned out to resemble a multilayer sandwich comprising many very thin layers of aluminum between layers of CFRP, all bonded together with epoxy.

The innovative aspect of the technology at that time was that the prepregged composite layers could be laid down in different directions to cater for specific stress conditions (much as is now common on many composite components). This meant that the resulting panels were extremely strong, yet light.

As the GLARE sheets are bonded together they can be handled in the manufacturing process like sheets of aluminum, using conventional techniques. Compared to conventional aluminum, GLARE panels are more resilient, have greater corrosion and fire resistance—and are lighter. They require less inspection and maintenance and have a long lifetime. Major structural panel sections on the A380 have GLARE panels.

The pace of the metallics revival is quickening. The re-emergence of metallic solutions as alternatives to future wing structures, for example, is an area that is being actively developed by **GKN Aerospace**, a global Tier 1 supplier that has a very sizable stake in both metallic and composite structural manufacturing for all the major aerospace constructors.

The company believes that additive manufacturing (AM) presents a massive opportunity to create complex shapes, some of which would be impossible to manufacture using conventional methods, with higher functionality and different materials.

Using AM techniques, materials can be fused to form objects from 3-D models, building up structures iteratively instead of taking forgings and then

machining material away. AM can produce highly complicated near-net-shape geometries with a good surface finish and, by almost eliminating the machining process, can make great savings in cost and carbon emissions.

GKN has invested heavily in exploring many different associated technologies but is presently focusing on processes such as electron beam melting, selective laser melting, and direct metal deposition techniques. It believes the potential for advanced welding and joining processes, such as laser welding, linear friction welding (LFW), and friction stir welding, is very applicable for future wing structures.

Laser welding techniques developed by GKN have been used on the European Ariane rocket nozzle and are now being applied to critical engine structures on the latest **Rolls-Royce** Trent XWB. They also are being studied for new aerostructures applications. LFW joins two items of material by rubbing them together until the surface gets hot enough to become plastic. A load then forces them together forming the joint. The technique can form near-net-shape engineered blanks, considerably reducing build costs. This has been developed to reduce the amount of waste material that can emerge from a forging (up to 90%).

The company is also looking closely at using LFW with titanium as well as dissimilar materials and alloys. It believes friction stir welding could replace today's bolted and riveted metallic joints with large panels. This solid-state jointing process forces together parts under load with a rotating tool, heating and stirring the plasticized metal to bond the components.

The benefits are many and include reducing component weight, improving fatigue performance, reducing the parts count, lowering design and assembly costs, and making maintenance easier.

Little wonder then that at the front line of aerospace structural manufacturing, metallics are well positioned for a significant comeback. ■



INCREASE VEHICLE EFFICIENCY, LOWER EMISSIONS

WITH TECHNICAL STANDARDS & RESOURCES FROM SAE INTERNATIONAL

Automakers are in overdrive to meet the U.S. federal mandate for a 54.5-mpg fleet average in the 2025MY—that's in addition to a bevy of other upcoming governmental fuel economy and CO² emissions regulations from around the globe they and commercial vehicle makers alike must comply. Meanwhile, ever-rising gas prices have made improving the effectiveness of fuel burned an even greater priority in the aerospace industry.

Whatever the vehicle sector, "increased efficiency and lower emissions" has become the mantra of the day with solutions as varied as the engineering challenges each one presents. Yet regardless of the path—or paths—taken to achieve sustainable, eco-responsible transportation, industry need only look to one organization as their partner for doing so.

Through its market-driven, voluntary consensus standards program, SAE International has worked hand-in-hand with the ground vehicle and aerospace industries for over 100 years advancing technology to ensure vehicle safety and efficiency. Offering the largest libraries of intellectual property focused on mobility technology, the past and current work of the global engineering community can be referenced for developing tomorrow's greener vehicles.

EXPLORE

- Advanced Materials
- Alternative Fuels (including EVs)
- Advanced Internal Combustion Engines
- Emissions
- Fuel Economy
- Aerodynamics
- Advanced Diesel Technology

SAE's vast library of mobility engineering information—available in formats ranging from technical standards, papers, and books to media, training, and events—on technology topics for use in improving vehicle efficiency and lower emissions.

JOIN COLLEAGUES

in advancing technology for ever-more lean and clean vehicles through the SAE Standards Development Program.

STAY CURRENT

with a complimentary subscription to SAE Technology E-Newsletters.

LEARN

how you can receive a free SAE Fuel Efficiency Industry Report.

Do this and more at
engineering.sae.org/2013emissions

SAE INTERNATIONAL

United States +1-724-776-4841
Europe (Aerospace Standards) +44 (0)207-034-1250
China +86-21-61577368
www.sae.org



HIGH HOPES OR JUST DREAMING?



A look at how Asia's aircraft manufacturers are trying to break into new markets to challenge the status quo.

by Richard Gardner, European Editor

For the past decade the fastest growing aerospace sales have been in Asia, which has done much to boost Western plane-makers at a difficult time in their own markets. This situation has led regional nations to look on enviously at the multi-billion dollar rewards that can flow from successful advanced aircraft programs, and they have concluded that they should have more of this business for themselves.

The new Asian powerhouse at present is China, but South Korea and Japan are also anxious to expand their aerospace exports. The real challenge is how to get to a stage of manufacturing maturity that can attract market credibility.

Today's customers already have plenty of product choice and they know the suppliers they can rely on. By definition any newcomer in this global market has little or no such

history, and by the time an all-new program has been given an artificial momentum (aspirational rather than demand-led), probably aided by government subsidy, the competing Western suppliers have already moved on to improve their own offerings.

This is what faces the Asian aerospace start-ups, and both India and China are now showing evidence of over-heating their economies in the rush to high-tech industrialization. As the Western economies falter, the market for new Asian products is also under increasing pressure, so there are no free rides on the journey toward transforming from a wannabe aerospace player to a serious global competitor.

China's long march

Until comparatively recently, the People's Republic of China had no real domestic aerospace industry that was capable of developing and bringing forward indigenous aircraft designs and systems that were anywhere near Western products in quality, reliability, or performance.

Military programs were always shrouded in secrecy, but Chinese output was of little serious concern to Western military analysts who kept a close watch from spy satellites, and other means, on what was under test or entering military service. In broad terms, everything seemed years behind Western equivalent programs and relied very much on "cloning" existing Russian designs via reverse engineering.

When they did this to the highly capable **Sukhoi** Su-33 fighter, and put it into production (without any license-fee complications) to create the J-15, the





AVIC is basing its initial civil aircraft products closely on Western and Russian designs, as can be seen from these models of the proposed MA600 and MA700 regionals, which look very similar to the Franco-Italian ATR family. (Richard Gardner)

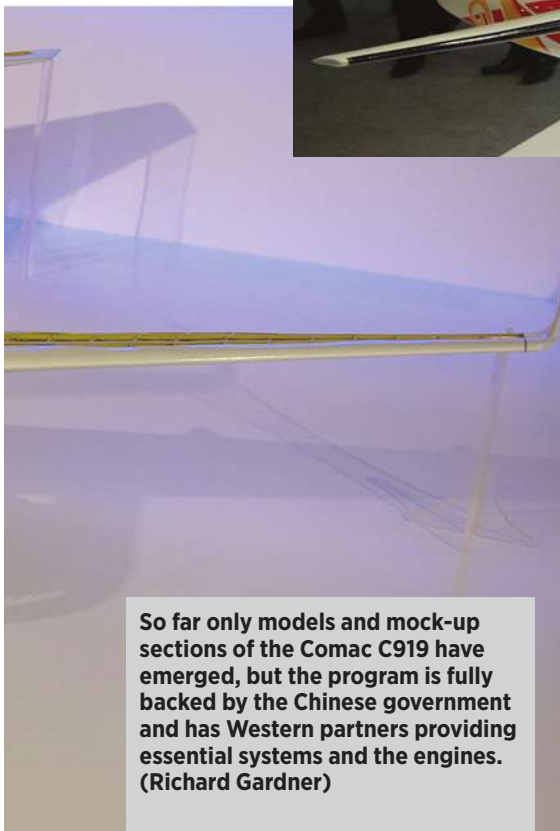

So far only models and mock-up sections of the Comac C919 have emerged, but the program is fully backed by the Chinese government and has Western partners providing essential systems and the engines. (Richard Gardner)

know-how, and new joint venture projects have been established by most of the big Western aerospace suppliers.

At first, this covered components but has gradually grown to include sub-assemblies and complete aircraft. These range from business jets and small transport aircraft to major sections for **Boeing** and **Airbus**, and complete A320s off a Chinese final assembly line. As this experience has been absorbed, it was inevitable that China would wish to offer its own aircraft families for the commercial sector.

Not content with local assembly of the A320 line, China has funded its main civil aerospace manufacturer, Commercial Aircraft Corp. of China (**Comac**), to launch its own similar size 150-180 seat twin jet, the C919, which is to be powered by the latest **CFM** Leap 1-C turbofans. This program aims to present a new-generation 737/A320 replacement design using fuel-efficient engines, modern cockpit and fly-by-wire controls, and the use of the latest metal and composite airframe materials.

The C919 already has domestic orders for an impressive 380 aircraft, which might otherwise have been placed with Boeing and Airbus, but these market leaders see this as aimed mostly at meeting Chinese needs while having limited export potential.

Others, including some Western low-cost airlines who might well appreciate a third supplier option, are more positive about China's aviation plans for the future and are adopting a wait-and-see attitude before committing to firm orders. It remains to be seen whether the optimism is well founded, but Comac, with almost unlimited state financial support, has announced that it fully intends to build a whole family of airliners, including widebody 250-350 seat aircraft, to compete with Boeing and Airbus.

For the time being, China realizes that to stand a chance of giving its new products a wider customer appeal, it must use key systems and components from established Western suppliers, so international partnerships are essential.

Comac has signed a collaborative agreement with **Bombardier** to work together on both the C919 and the 130-seat Bombardier C Series. This covers flight test activities and areas of customer service including training, technical publications, and parts distribution. Comac has also signed deals with **UTC Aerospace Systems** for key systems on the C919 including cockpit and throttle controls and passenger door systems, and there is a separate JV between UTC and China's Aviation Industry Corp. (**AVIC**) to develop and manufacture the aircraft's electrical power supply system. Comac has scaled back the composites content in the C919 to reduce program risk but has a target of 16 JVs covering most areas of the structure and systems.

When Airbus made the decision in the 1990s to set up a Chinese-located A320 final assembly line, it answered its critics on the strategic implications of this by pointing out that its own advanced R&D efforts would continue toward a visionary path beyond whatever China might do based on A320 era technology. This is happening now with the emergence of the C919, while both Airbus and Boeing continue to develop even more advanced generations of their two most

Russians were not too happy. Even now, China is still largely dependent on Russia exporting supersonic aero-engines to power its home-grown military aircraft.

Engines currently remain a weak link in Chinese aspirations for a comprehensive aerospace self-sufficiency, but things are moving ahead rapidly. The country has invested enormously in educating new aerospace engineers as well as seeking as much knowledge as possible on modern Western engines and new technologies. This has enabled a great deal of high-tech catch-up with the West over the past decade, and the capability gap is closing.

Western nations have shown little reluctance to sign up cooperative partnerships with Chinese companies to compete in this expanding market. This has brought a huge expansion in manufacturing capacity and technical

HIGH HOPES OR JUST DREAMING?

Japan is pinning its aerospace export breakthrough on its Mitsubishi MRJ jetliner, but it is up against tough competition from established regional supplier, Embraer.



South Korea is now making headway with its T-50 Golden Hawk, which comes in two versions for advanced training or as a light attack fighter. (Richard Gardner)



on the supply of the latest Sukhoi Su-35 fighters, but the manufacturer is concerned that only a few may be bought and then cloned once again.

China's aerospace activities extend into space launchers and satellites and also helicopters, where it is involved in a growing number of joint ventures with major Western manufacturers, including **Eurocopter**.

Helicopters, such as the new AC313, are part of China's aerospace expansion plan that builds on today's JV partnership experience with such Western companies as Eurocopter. (Richard Gardner)



Rising sun's rising star

Japan's status as the leading Asian economic driver may have been overshadowed in recent times by China, but it has been the major regional aerospace manufacturer for decades, producing license-built U.S. aircraft, but also contributing major structural components in partnership with others on global programs. It has also produced its own military aircraft designs for the Japanese Forces, though the country's post-1945 constitutional laws prevent the export of military equipment, other than for use in humanitarian tasks.

Following the recent election of a more nationalist-inclined government in Japan, it is thought likely that policy may change, allowing the country's aerospace industry to become more competitive across a broader range of aviation products, military as well as civil. However, for the moment the main national focus for aerospace expansion is arriving in the shape of the **Mitsubishi MRJ**, a regional jetliner offering 70-90 seats, with the possibility of a 100-seat version following. This is the country's first medium-size civil program since the YS-11 turboprop airliner of the 1960s.

Mitsubishi has long been an important manufacturing partner on Boeing commercial airplanes, which has grown over the years from producing around 15% of the structure on the 767 to nearly 30% on the 787. The

popular 150-seat products, as well as investing in more radical solutions for a 2030s in-service timescale.

As the sales backlog of thousands of Boeing and Airbus 150-seat airliners grows, the C919 may find a market niche among those airlines that do not want to wait for up to five years, or longer, to get their hands on new aircraft deliveries. Though the development timescale has slipped several times, the target for entry into service for the C919 is now late 2016.

In the meantime, China's technologically modest 100-seat Comac ARJ21 regional jet (an MD-95/B717 clone), which first flew in 2008, has still not achieved certification, let alone service entry. A shortage of engineers has been given as the reason why this program has taken so long, and the **FAA** has been helping in safety certification.

A similarly "cloned" ATR look-alike turboprop regional airliner is also being developed for China's growing internal airline network. So far, there appears to be little external customer interest, but while China establishes a more credible family of civil aerospace products, and increases its marketing efforts, it does not yet have global spares and engineering support with the critical mass to make an impact on major airlines.

China continues to reveal development examples of advanced military jet fighters, with visual stealth characteristics, but it is not known if the complex coatings and angular aerodynamics offer comparable degrees of radar reduction to that on such types as the F-35 and F-22. While China's latest military jets are looking more modern, with features taken from current Western and Russian designs, the large-scale operational use of such aircraft appears to be well into the future.

Of more concern to Western analysts are large numbers of current-generation jets, such as the J-10 and J-15, armed with long-range stand-off missiles, which pose a potential threat to economic infrastructure and military targets in the region, including aircraft-carriers. China is negotiating with Russia



Chinese military aircraft are also closely based on existing designs, such as this armed UAV, which could be mistaken for a General Atomics Reaper, or the latest two-seat advanced trainer, which bears a close resemblance to the Alenia M-346 and its close cousin, the Yak 130. (Richard Gardner)

company's experience in producing large structural components from composite materials led it toward making its own regional jet design a largely composite aircraft. This, it was claimed, together with the use of the **Pratt & Whitney PW1200G** geared turbo fan (GTF) and advanced aerodynamics, would give customers the lightest and most efficient regional jet on the market.

That was in 2007, and six years on the program has lost much momentum with several major changes in design and specification. Out has gone the all-composite fuselage and wings, to be replaced by an aluminum structure, with composite fairings, spoilers, control surfaces, and tail units. The composite contribution is now down to around 12% of the total aircraft weight.

As Mitsubishi is the launch customer for the new GTF engine, it cannot avoid having to bear the introductory challenges of integrating an all-new engine on an all-new airframe. It undoubtedly underestimated the scale of the challenge, as the first flight was scheduled for 2011, but is now expected to take place before the end of 2013.

Many expect a further slippage, but launch customer **All Nippon Airways** is due to receive its first aircraft in 2015, so the flight test schedule, involving five flying aircraft and two ground test specimens, will have to go very smoothly to keep to the twice-revised target certification date.

Other regional programs

South Korea has built up a large aircraft manufacturing capability for military aircraft. **KAI** has produced many U.S. fighters under license over the



China and Pakistan have cooperated on the FC-1 fighter, and a new trainer version is being introduced for export. (Richard Gardner)

years, and with the help of **Lockheed Martin** has developed a new supersonic trainer/light strike aircraft, the T/A-50 Golden Hawk. It is now being exported in Asia and also offered in competition with other advanced jet trainers for global orders, including a possible T-38 replacement program in the U.S. South Korea also offers a light trainer, the KT-1 for initial flying training.

Indonesia was expanding its aerospace manufacturing capabilities throughout the 1990s, but its ambitious dream of designing and building a series of indigenous regional transport aircraft came crashing to Earth when state supplier **IPTN** failed in the face of rapidly rising development costs and the collapse of the sponsoring government.

Today, the long-standing cooperative partnership with Spain's former **CASA** group, now part of Airbus Military, has been partly revived to restart joint production of small transports, including the CN-235. These will be used for internal transport in Indonesia but will also be marketed for export to regional customers.

India, as a subcontinent beyond the scope of this feature, nevertheless has its fortunes closely linked to wider Asian developments. It has a very active aerospace industry and is producing indigenous military aircraft ranging from helicopters and transports to advanced fighters, built and assembled by **Hindustan Aeronautics**.

Fear of an expanding China and a hostile Pakistan on its borders motivates high defense spending in India supported by a very capable domestic R&D organization. Future expansion into civil programs is supported by government, with design work starting on an Indian 150-seat jetliner, though it is widely believed that if this progresses into eventual production it will struggle to compete in export markets. ■



IMPROVE INTERIOR PACKAGE DESIGN, INCREASE VEHICLE SAFETY, AND ENSURE INTERNATIONAL COMPLIANCE WITH THE SAE H-POINT MACHINE

A three-dimensional manikin that provides the physical representation of driver H-points, the **H-Point Machine (HPM)** is used to define and measure vehicle seating accommodations. Offering a deflected seat rather than a free seat contour as a reference for defining seat space, it is a vital tool in the design of interior packages.

Available through SAE International, the *HPM* is used in conjunction with SAE Standard J826 and is currently referenced in various federal and international regulations including NHTSA's FMVSS in the US and ISO standards. Utilized in testing for compliance to such regulations involving impact/crash, head restraint, or vision, it is the required safety certification tool for vehicle production in many countries around the world. Additionally, those who need to locate seating reference points and torso angles as reported by manufacturers employ the *SAE H-Point Machine*.

SAE provides comprehensive support for the *HPM* including, calibration, spare parts, and maintenance. And for advance design and research applications, the **HPM-II** is available, which includes reformed shells for a consistent and reliable fit in bucket seats, an articulating back for lumbar support measurement, and the ability to measure the H-point without using legs resulting in simpler installation.



View a free demonstration video at www.saeinternational.cn/hpoint/ to see how the HPM-I and the HPM-II offer a means of obtaining passenger compartment dimensions.



SAE INTERNATIONAL

+1.1.724.776.4841

www.sae.org

China

+86.21.61577368

SAE is an international body of engineers and practitioners dedicated to the advancement of mobility technology. Based on the fundamental of providing a neutral platform for collaboration and informed dialogue, SAE has been providing the common engineering requirements for new vehicles, advanced technologies, and applications since 1905.



Many sensors provide data that keeps portable cranes from Manitex from toppling over when they have heavy loads and unstable footing.

SENSITIVE TO SAFETY

A growing number of digital sensors are among the tools being used to make sure failures are rare and injuries are even more infrequent.

by Terry Costlow

Safety usually isn't first on the list for equipment buyers, but ensuring that equipment operates safely and reliably is a primary concern for developers throughout the supply chain. A growing number of digital sensors are among the tools being used to make sure failures are rare and injuries are even more infrequent.

Sensors provide the input for electronic controls that help manage an increasing number of activities. They monitor loads, angles, speed, and many other work-related parameters while also helping to improve safety when vehicles are on highways.

No tipping

Off-highway equipment typically works in environments that have hills and soft ground, so preventing rollovers is often a challenge. Sensors must determine the position of the cab, recognizing any change in angle. In many types of equipment, from loaders to cranes, data must also account for the effect of loads.

The bigger the vehicle, the more difficult it can be to collect all this data and analyze it. Many systems combine multiple sensors and processors within inertial measurement units (IMUs) that make sure vehicles remain upright. In cranes, sensors must be accurate and processors must run at high speeds to maintain stability.

"The cab can be 3 or 4 m away from the load," said Larry Weber, Global Strategic Marketing Director for Sensing and Control at **Honeywell**. "The IMU often sits on top of the cab. It needs to constantly calculate the angle to see if the crane is at an unsafe angle. As the weight goes farther from the center point, a lot of calculations have to be made in real time."

System designers are employing solid-state devices including microelectro-

mechanical systems (MEMS) devices to monitor motion. These digital devices often replace multiple modules, saving cost without sacrificing performance.

"Using digital measurements lets us eliminate a lot of components on a large jib," Weber said. "There can be as many as six discrete sensors on a jib."

Digital data can also help operators understand the position of loads. That can be an important factor when equipment is moving at slow speeds. Busy operators can overlook slow movements, but subtle movements can quickly add up to cause significant changes in load balancing. For cranes, that can be dangerous.

"Speed sensors on the winches let the operator know they're moving, even if it's at a very slow speed," said Scott Rolston, Senior Vice President of Strategic Planning, **Manitex**.

Other heavy-duty vehicles require different types of sensors. In mining and other areas where loads are very heavy, it's important to know that trucks aren't burdened with more weight than they can safely handle.

"Sensors can detect that a haul truck is overloaded and then can warn the operator," said Dave Schings,

SENSITIVE TO SAFETY

Honeywell provides a number of sensors that gather data from all parts of a crane.

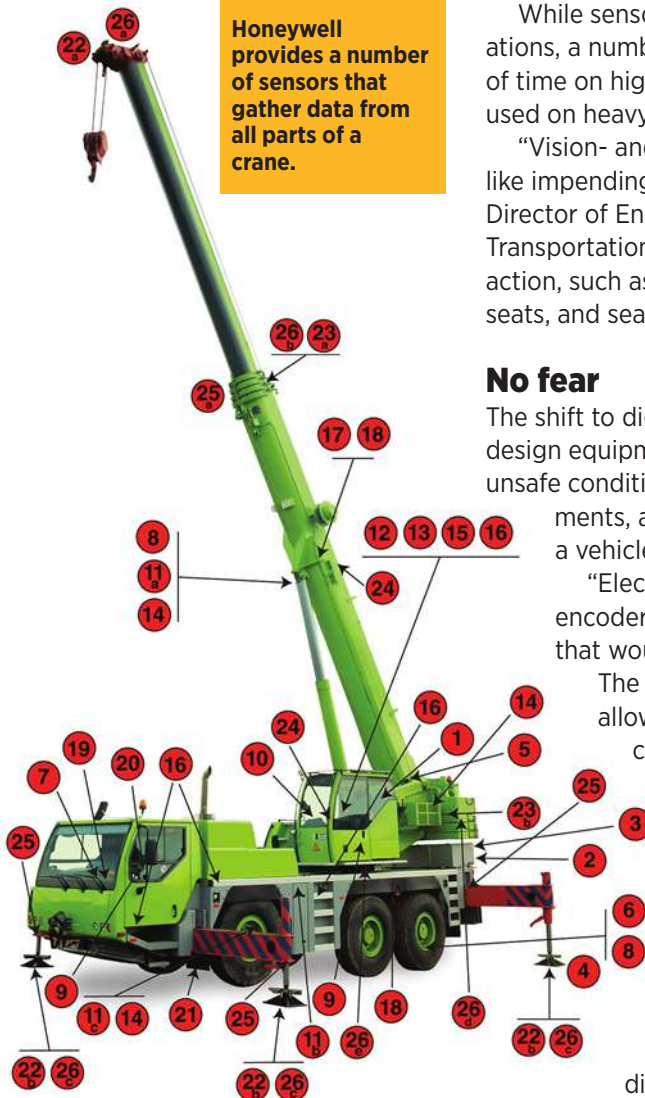

Functional Safety Technical Steward at **Caterpillar**. “Excessive overloading can create unsafe steering and braking characteristics.”

While sensors on booms and loaders are helping improve safety during operations, a number of other sensors are used on vehicles that spend a fair amount of time on highways. For example, trucks with cranes are adding safety systems used on heavy-duty trucks.

“Vision- and radar-based sensors are able to better warn drivers of situations like impending collisions and inadvertent lane departures,” said Joe Bolewitz, Director of Engineering for **TE Connectivity’s** Industrial and Commercial Transportation Business. “These same sensors also can trigger proactive vehicle action, such as automatic braking, haptic feedback in the steering wheel and seats, and seatbelt pretensioners.”

No fear

The shift to digital sensors makes life much easier for engineers who want to design equipment that runs close to the danger zone without moving into an unsafe condition. Digital technologies typically provide more precise measurements, and margins can more easily be programmed for each variation of a vehicle.

“Electronics gives us much more flexibility,” Rolston said. “With digital encoders, we can provide custom charts for each crane truck. In the past, that would have been very difficult to do.”

The ability to do complex calculations based on precise digital input allows developers and operators alike to press the limits of their vehicles. That lets design teams trim down safety parameters and boost payloads.

“In the past, we had to design in large safety margins based on simple load calculations,” Weber said. “Now we can provide real-time measurements that let operators carry heavy loads without compromising safety.”

The shift to digital sensing also makes it easier to give operators information that can improve their efficiency. Data can be displayed on programmable displays that can show many different types of data. The ability to change gauges and images for different types of operations lets systems show operators plenty of information in a format that’s easy to understand.

Guides direct developers to safe projects

Engineers tasked with designing electronic systems that meet high safety levels have a lot of standards and guidelines that can help them ensure that failures will be rare and that faults won’t cause injuries or serious damage when they do occur.

Using risk assessment to understand potential problems and reduce the likelihood of their occurrence has been one of the big trends over the past few years. These evaluations are now one of the earliest analysis steps during the design phase.

“A risk assessment is performed at the machine level to determine the safe state should an identified hazard come to pass,” said Dave Schings, Functional Safety Technical Steward at **Caterpillar**. “Risk assessments are conducted early in the new/updated product design cycle to identify hazards to operators or people working around machines.”

A range of standards provides guidelines for developers. While adhering to standards may be a headache during some aspects of development, most managers support their use. Using a structured design program reduces the chance of failure



Manitex uses a number of standards and guidelines to create safe products.

and provides documentation that can be helpful if problems arise.

“ANSI codes cover the design, and SAE codes cover the crane,” said Scott Rolston, Senior Vice President of Strategic Planning at **Manitex**. “We build a test bench and test the criterion for each operation. Generally, any failure results in setting the crane to a safe mode.”

Along with ANSI and SAE documents, **International Standards Organization** standards cover many different types of equipment. For functional safety suitable for the earthmoving industry, ISO 13849 is used to ensure safety-related electronic controls operate correctly, for example.

Other techniques help engineering teams meet customer requirements. Many of these strategies give engineers leeway to pick components that meet desired reliability levels.

“Systems have to be designed to Six Sigma levels,” said Larry Weber, Global Strategic Marketing Director for Sensing and Control at **Honeywell**. “When we approach OEMs, they don’t really care about the parts we use, they’re asking for a solution to their problems.”

Terry Costlow



Measuring the weight of a payload helps Caterpillar improve safety of heavy mining trucks.



Secure connections such as those from TE Connectivity are important for any safety-related equipment.



Honeywell's IMU performs plenty of real-time calculations to determine whether a vehicle is in danger of tipping.



In large work sites, monitoring other vehicles is an important safety factor, said Caterpillar's Dave Schings.

"Displays let us provide very clear, customized information for each crane," Rolston said.

No failures

When equipment designers are designing electronic systems that impact vehicle safety, field failures are a key concern. Redundancy provides high levels of fault tolerance, but it's expensive. Engineers must constantly balance the size and cost of duplicate parts with alternatives that provide similar reliability levels.

"Redundancy is used in highly safety-critical controls such as electronic steering controls for machines that travel on public roads," Schings said. "For less than highly safety-critical controls, we use components with higher levels of reliability along with increased diagnostics to detect component failure."

Components with high levels of reliability don't necessarily have high

levels of technology. Cables and connectors typically cause more faults than microcontrollers and sensors, so engineers have to make sure that these comparatively simple components don't cause a vehicle to stop progress at a work site.

"Connections must work every time, and the data cannot be compromised," Bolewitz said. "They must be immune to the harshest of environments—high vibration, temperature extremes, moisture, and all types of dirt and contamination."

No collisions

In today's marketplace, safety-critical, fault-tolerant, error-detecting, and error-correcting are all important aspects in the design of safety systems. But many off-highway work sites have many pieces of equipment that must operate in harmony. System designers are providing tools that will help operators avoid collisions.

"When there are multiple cranes on a site, you want to keep the jib arms from colliding," Weber said.

In coming years, safety may extend even further beyond the vehicle. Regulators in the U.S. and elsewhere appear quite interested in vehicle-to-vehicle and vehicle-to-infrastructure communications. Safety can be greatly enhanced when vehicles tell each other where they are.

"We also need to keep in mind that a safety system of today and the future is really a network of interconnected subsystems that seamlessly communicate and interact to provide a desired outcome," Bolewitz said. "Today's subsystems cross-talk within a single vehicle; tomorrow's vehicles will communicate with each other, as well as with roadside infrastructure." ■

SAE INTERNATIONAL PREPARES YOU TO DELIVER ON THE JOB.

SAE International offers you education and training resources in the areas that are shaping mobility.

- Instructor-led programs taught by industry experts
- Online, on-demand options
- On-site training designed for your organization's specific needs

Stay current on the latest technology, increase your knowledge, and positively affect your organization's bottom line with professional development from SAE International.

First-time offering in India!

Vehicle Dynamics for Passenger Cars and Light Trucks
23-25 January 2014 - Chennai, India.

Presented by SAE International & SAEINDIA

Find full course description here: training.sae.org/seminars/99020
To Register, or for more details (including India pricing) contact:
Mr. D Seshadri, Deputy Director - Marketing, SAE India
seshadrid@saeindia.org

Visit www.sae.org/training to view all SAE International professional development opportunities, schedules and course information.

P136546

Seminars



Engineering Academies

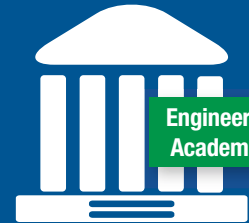

e-Learning



Corporate Learning Solutions



SIMULATING OFF-HIGHWAY HYBRIDS



Ricardo developed a flywheel-based hybrid demonstrator system to illustrate the utility of a flywheel hybrid system that simulations showed would be well-suited for excavators' duty cycles.

“Programs to redesign off-highway equipment for significantly improved efficiency are receiving widespread attention with our customers today,” said Tom Apostolos to **SAE** magazines. He is the President of **Ricardo**, the consulting engineering firm. Though the desire for fuel efficiency is the same for all vehicle makers, “the off-highway market has different vehicle imperatives than the on-highway market,” he remarked. Some of the differences he noted include a wide variety of vehicle models—with diverse duty cycles—and low production volumes.

These challenges make it hard on the business case, for both OEMs and suppliers. The trick is to build as many common components spread over multiple applications as possible. Also, since reliability is a must, hybrid systems require extensive validation before OEMs will risk putting them into production, Apostolos said.

Hybrid choices—electrical, hydraulic, flywheel

Lack of production experience is another challenge. “Today, there are still relatively few production hybrid vehicle offerings in the off-highway market,” said Apostolos. “Initial demonstrator vehicles and first production applications have deployed predominantly electrical technology.” He believes that, depending on requirements and duty cycles, electric hybrid technology is a good option. “A potential key benefit is providing exportable electric power to operate equipment at remote locations, which can improve the value and productivity associated with electric hybrid vehicles,” he said.

Hydraulics is another option. Many off-highway vehicles already have high-pressure hydraulic systems installed. Hydraulic hybrids use accumulators rather than

batteries to store energy. **Caterpillar** has already released such a hybrid excavator, and Apostolos reported that **Hyundai** is scheduled to release another next year. “Applications that have high power, but not particularly high-energy storage requirements, are typically in the sweet spot for hydraulic-hybrid options,” he said. Using flywheels to store energy is another option. Ricardo pioneered such a high-speed flywheel on a demonstrator excavator.

How does computer simulation help? “Due to the diversity of vehicles and duty cycles, the relatively modest hybrid experience, and the importance of good financial payback in the off-highway market, vehicle system simulation tools can be critically important,” explained Apostolos. At the concept stage, simulation tools are used to develop architectures, estimate benefits, develop preliminary cost estimates, and develop the “hybrid supervisory control concepts” as well as plan out functional integration. As the design matures, simulation tools are used to refine costs and benefits, detail out control strategies, and evaluate performance specifications. Control software is especially vital. “Getting the hybrid supervisor right is an important part of making the potential benefits real,” he said.

With customers squeezed by fuel costs, off-highway OEMs are showing some interest in developing hybrid equipment. CAE simulation tools are needed because of lack of experience with such devices. Their functional complexity requires control system simulation throughout their lives.

by Bruce Morey

SIMULATING OFF-HIGHWAY HYBRIDS

Caterpillar developed its own dynamic simulation tool, DYNASTY, to help develop control system models. The tool remains useful through the life of the program to optimize control strategies.

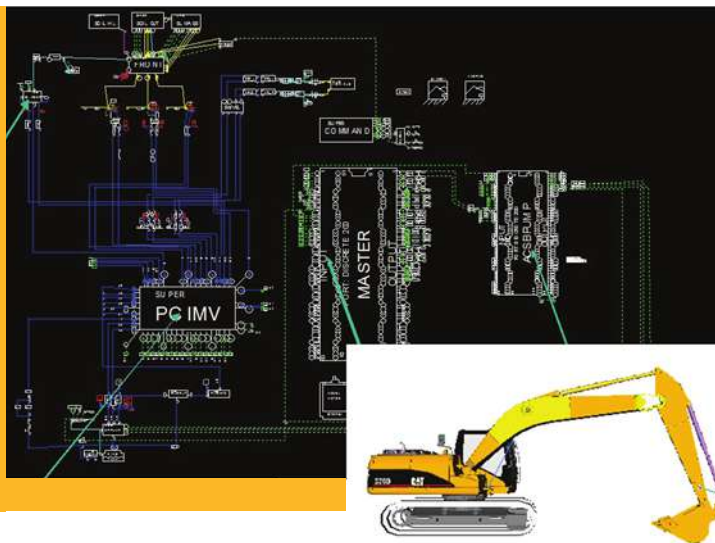

Apostolos reported that Ricardo is developing IGNITE, a next-generation system simulation package. IGNITE will have libraries of vehicle system building blocks that users can select to quickly model complete conventional and hybrid vehicle architectures, with native design and optimization tools.

Caterpillar chooses hydraulics

This year, Caterpillar launched its 336E H hybrid excavator. To help in the design process, Caterpillar relied heavily on simulation tools, starting with simple spreadsheet energy analyses to eventually using sophisticated mixed-model simulations, according to Randy Peterson, Advanced Technology Development Manager for Caterpillar, in an interview with SAE. Mixed-model simulations, for example, incorporate CFD and linkage models with kinematic simulations of vehicle dynamics. Caterpillar uses its own dynamic simulation tool called DYNASTY, which integrates physics-based complex component and vehicle level dynamic models to predict machine performance. It also uses other simulation models or collected test data as inputs.

Why choose hydraulic only for the 336E H? Maintenance and supply chain issues contributed. "Existing excavators use hydraulic components such as pumps and cylinders to do the heavy lifting," Peterson explained. Dealers and customers alike would need little additional training to service an all-hydraulic system, and robustness—real or perceived—would be higher. Another reason to choose hydraulics was efficiency. "One of the interesting things we learned in our computer simulations is that a hydraulic hybrid is very efficient. Once the

accumulator is heated to a steady state, it is 98% efficient and it is a very simple, robust system," said Peterson.

Choosing that right way is why control systems start their life in simulation, according to Peterson. "Without the computer simulation up front, we would never have been able to get where we needed to be," he explained. As development progresses, the control system is transitioned to a hardware-in-the-loop prototyping environment and eventually calibration with human tests on the actual machinery. However, the original simulation is never discarded. In fact, it remains configured and used during the life of the program. "We use simulation to optimize the control strategy, using DoE to modify parameters, then check with the human operator," he said. "There is no real process where modeling ends."

Taming complexity, maintaining fidelity

Model-based design, especially using Matlab or SIMULINK models from MathWorks, is common in developing such complex control systems. "We think deriving traditional physical models using causal techniques is becoming obsolete," said Paul Goossens, Vice President for Maplesoft in an interview with SAE. His company's MapleSim software uses symbolic processing based on the international Modelica standard to ease the task of deriving plant models that form the heart of model-based design. "These models are then used in hardware-in-the-loop simulations, with faster run times based on our experiments," he said.

While Modelica as a language is nonproprietary, the MapleSim interface and component libraries are where Goossens' company adds value. He explained that MapleSim has a host of existing electrical component models such as batteries, motor generators, and electromechanical actuators. It also uses a library of hydraulic components, such as pumps, motors, valves, and accumulators, some of which they in turn source from Modelon.

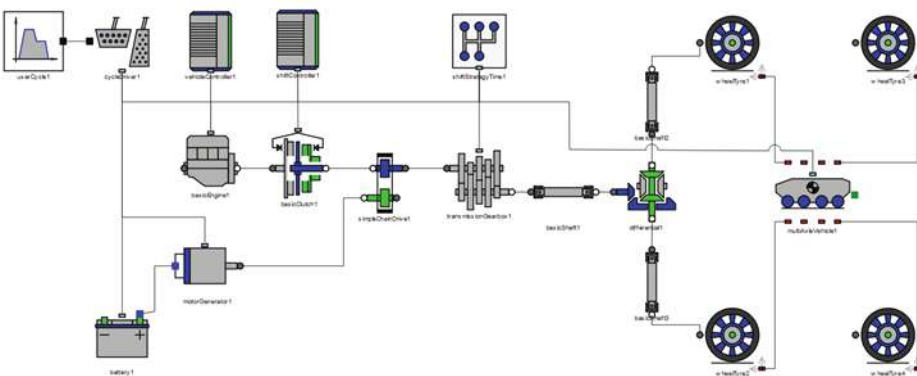

Ricardo is developing a system simulation package it calls IGNITE. It will have libraries of vehicle system building blocks that users can select to quickly model complete conventional and hybrid vehicle architectures.

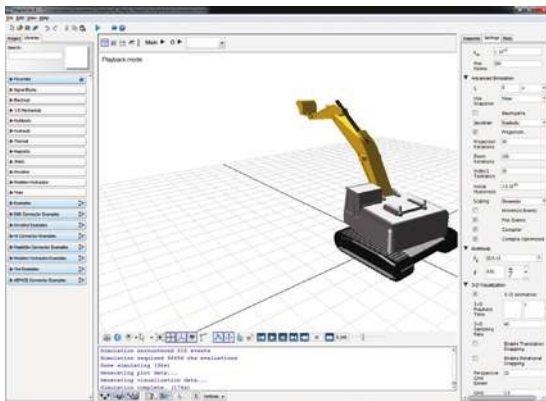

Maplesoft's MapleSim modeling program uses the nonproprietary Modelica language with component models to devise working behavior models and testing of control system strategies.

"For electric and hybrid-electric drives, the battery pack is especially difficult to model, since it requires modeling complex chemistry and thermal equations that are coupled," he said. The battery behavior also depends on the load of the system, with the potential for thermal runaways dependent on the electrical demand of the system. "Using symbolic technology provides many advantages in solving these linked, dependent equations," he said.

He also noted that hydraulic components, interestingly enough, present some of the toughest modeling challenges. "They require much detail in fluid flow, losses, and other factors, more so than electrical components," he said.

Growing need for mixed models

The demands on his customers for higher fidelity models are forcing some changes. "One area that we are seeing as increasingly important is the demand for mixed-models, that is between 1-D tools like MapleSim, and FEA and 3-D models," said Goossens. Customers are looking to use the results of detailed FEA models to implement, for example, flexibility, vibrational or thermal effects in the 1-D models. This improves accuracy through fidelity, while preserving the speed and utility of 1-D models.

Another future development that Goossens is alerted to is the continuing development of average-value (sometimes referred to as "mean-value") models. This is rooted in the never-ending trade-off between high-fidelity computer models that drain computer resources (and take a long time to run) vs. low-fidelity, less "accurate" models that run in acceptable times.

"By starting with the highest fidelity model, one can go through a model order reduction process to convert it to an average-value

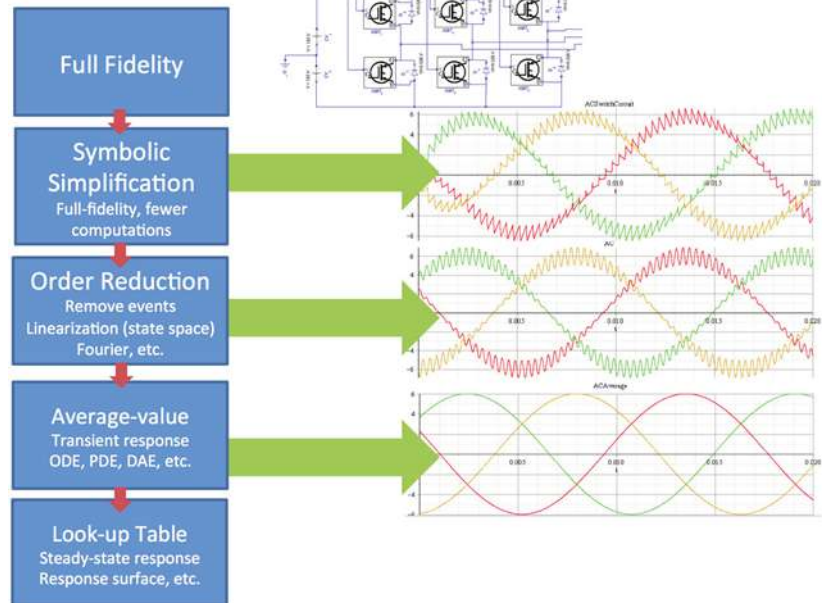

Model reduction through a mathematically rigorous process is critical for understanding what reductions have been made and why. Through the use of advanced symbolic technologies, Maplesoft is working on tools to help in this process.

model" that will have utility in a practical computer simulation, he explained. "At the moment, this is a fairly manual process and requires considerable knowledge on the part of an engineer to do that." Rigor is required in this process, and Maplesoft is actively involved in developing mathematical methods and tools for model-reduction to help the engineer with this process. Stay tuned.

Mechanical electrical integration challenges

Simulation is just as important at the component level as it is for entire systems, and for predicting interactions of mechanical and electrical driveline components, according to Barry James, Technology Director, Simulation Technologies for Romax, in an interview with SAE. "Intensive simulation-led design used for the best conventional powertrains, particularly at the crucial early stages, remain key to achieving product design objectives." He noted a common failing is to treat the electric motor and transmission in hybrid EVs as distinct elements. Transmission error from gears and torque ripple from motors cause vibrations from each. "As the resonant frequencies of the complete structure will be very different from its individual parts, the excitation of the components will yield a very different vibratory response if their performance is considered in isolation," he explained. This results in system problems not evident in each as components. For example, electric motor and transmission individually rated as extremely quiet may be unacceptably noisy when combined into an EV powertrain.

"When matching an electric machine to a transmission, it is possible to have up to 2000 potential design combinations of layout, ratio, and motor configuration," he explained. To expedite the design process and achieve higher levels of effectiveness, Romax has developed a more streamlined approach, according to James. This enables Romax to rapidly assess not just the effectiveness of a design in terms of a given drive or duty cycle but also its robustness. "Further innovation allows all design variants within the whole design space to be considered this way very early in the design stage," he said. ■

SAE INTERNATIONAL JOURNAL OF FUELS AND LUBRICANTS

Our leading international journal offers scholarly reports of research focusing on fuels and lubricants in automotive engineering. It reflects the transitions from the traditional to the cutting-edge realm of fuels and lubricants technology in the fields of:

- Fuel properties and effects
- Alternative and advanced fuels
- Lubricants
- Surface engineering and automotive tribology
- Additives
- Deposits
- Fuel, lubricant, and additive effects on engine performance, emissions, fuel economy, catalyst technology, and environmental implications

Contact us today! www.sae.org/journals

SAE Customer Service

1-877-606-7323

1-724-776-4970 (outside U.S. & Canada)

CustomerService@sae.org

Global VEHICLES

Kubota goes deluxe with two new models for its M-Series

Kubota Tractor's M6060 and M7060 are its two newest models in its premium M-60 utility ag tractor line.

The deluxe M7060 12-speed-transmission ROPS model will benefit farms of all sizes, says Kubota, since it's able to tackle applications such as hauling, material handling and loader work, snow removal, and operating hay tools.

"We are continuing to grow and expand our utility tractor offerings for

customers big and small," said Paul Williams, Senior Product Manager, Kubota.

M7060 deluxe models "elevate Kubota's M60-Series to a new level" with a 71 net hp (53 kW) V3307 common-rail system (CRS), 12-speed transmission, high-flow hydraulic system, electric-over-hydraulic four-wheel-drive engagement, and 540/540E rpm PTO.

The CRS electronically controls the

timing and amount of injected fuel providing high-pressure injections in stages, rather than all at once, for an optimal combustion rate that results in greater efficiency, better fuel economy, and less engine noise. It's combined with a DPF and EGR to meet emissions regulations.

The 12-speed HDC transmission provides progressive movement of the gears for increased efficiency as the operator moves through all 12 forward and 12 reverse gears. The high-capacity hydraulic flow provides 16 gal/min (60 L/min), increasing fuel economy with lower engine speed and lowering operational noise when working with a loader. This four-wheel-drive model is equipped with electric-over engagement, allowing operators to engage four-wheel drive at the flip of a switch.

Auto braking from two-wheel-drive mode reduces front tire wear, while providing efficient braking action. Hydraulic wet-disc brakes are standard equipment.

The 540 PTO can operate in 540E (Economy) mode for light-duty applications, increasing fuel economy and reducing operating noise while running implements such as a post hole digger or boom sprayer. The M7060 is also Tier 4 compliant, minimizing emissions.

To help reduce operator fatigue and stress, the V3307 CRS engine has been



Also new is Kubota's M-Series front loader, built in Georgia, which it says was designed with the farm in mind. The LA1154 front loader is performance-matched for optimal operation with the M60-Series.



Kubota's Hydraulic Shuttle for the M6060/M7060 eases shifting between forward and reverse. With the Hydraulic Shuttle, a column-mounted lever located next to the steering wheel, the operator no longer needs to depress the clutch whenever direction is changed, boosting productivity.



The M6060/M7060 engine features a new electronic control of engine rpm. Activating the system keeps engine revolution nearly constant with a push of the switch, preventing a reduction in PTO speed and enabling stable operation.



The LA1154 front loader is also equipped with a series valve with regenerative function, which allows simultaneous lift and dump or rollback and raising of the bucket.

specially designed to minimize noise and vibration via several innovative technologies. Noise is reduced through a ladder frame crankshaft support, giving the engines a stiffer structure and thus lower noise. Also, a gear train on the flywheel side reduces the gear chattering noise caused by crankshaft torsion. Vibration is lowered through the application of compact, built-in balancers.

Another addition to the M60 line this year is the M6060, available in two- or four-wheel drive and equipped with a Kubota V3307, 63.5 net hp (47 kW) diesel engine. This model features standard wet-disc brakes. Hydraulic shuttle clutch is designed specifically to meet demanding loader work; this feature sets the M6060 apart from other units on the market with a dry clutch.

Other features include an ergonomically designed console, with an added direct shift linkage and hydraulic remote levers that are positioned for easy operation. The PTO can now be engaged with a simple push-and-turn motion of a large

yellow knob. The V3307 engine has been updated to Tier 4 emissions standards with a CRS electronic fuel component with electronically controlled governor, both of which increase engine performance while saving fuel.

Also new is Kubota's M-Series front loader, built in Georgia, which it says was designed with the farm in mind. The LA1154 front loader is performance-matched for optimal operation with the M60-Series.

The loader is also equipped with a series valve with regenerative function, which increases performance, productivity, and quick cycle times. The series valve allows simultaneous lift and dump or rollback and raising of the bucket.

Fully integrated with the tractor's design, the loader has a sleek look and increased operator visibility. In the power position, the LA1154 has a maximum lift height of 117.2 in (2977 mm) and lift capacity (at pivot pin) of 2928 lb (1328 kg).

Jean L. Broge

Scania employs simulation to produce customer-specific trucks

The Swedish company **Scania** has struck a unique balance between mass production and customization. The manufacturer of trucks, buses, coaches, and industrial and marine engines uses a modular vehicle configuration system to provide customers with vehicles tailored specifically to their needs.

Scania assembles vehicles from pre-engineered components connected to standard interfaces and then optimizes them for each customer's requirements. This system enables the company to create individual configurations for a large number of customers.

The modular customization approach has contributed to Scania's success but has also been a significant cost management challenge. Before delivering vehicles to customers, Scania had to determine whether they met customers' requirements for handling, comfort, and promised fatigue life under a variety of conditions. Traditionally, the only way to do that was to build a vehicle complete with custom hardware, equip it with sensors, and run it around a test track. This approach was expensive and inefficient for two reasons.

The first and most obvious is the cost of building a vehicle, paying highly skilled employees to configure it for testing, and then interpreting the data that comes from the test. The second and more onerous cost is making modifications if testing reveals a problem. At this point in the production cycle, Scania had hundreds of thousands of dollars invested in the vehicle's design. Every issue that required a modification or a redesign increased expenses geometrically because the company lost time against production goals as well as labor, material, and tooling costs.

Scania has improved its testing processes by integrating simulation software into the process prior to prototyping and track testing. Simulation has enabled the company to test more vehicle configurations at a lower cost and with less disruption than it took to

test just one configuration using its previous process. The new approach makes it possible to provide each customer with an optimized product, while keeping costs throughout the value chain at a competitive level.

“Simulation gives us the ability to explore design alternatives in the early stages of the design process,” said Anders Ahlström, Ph.D., Structural and Vehicle Dynamics Engineer for Scania. “The result is that we have been able to significantly improve the handling, comfort, and fatigue life of our vehicles.”

Scania used **MSC Software’s** Adams/Car multibody dynamics analysis software to create models of its vehicles, its 10-channel test rig, and its test track. In most cases, engineers can create a simulation model of a new vehicle simply by selecting and connecting Adams modules. They can then model the components as flexible bodies composed of either shell or solid elements using MSC Nastran finite-element analysis (FEA) software.

The simulations enable engineering teams to quickly evaluate functional virtual prototypes of complete vehicles and vehicle subsystems. Working in the simulation environment, engineering teams can exercise their vehicle designs under various road conditions, performing the same tests they normally run in a test lab or on a test track but in a fraction of the time.

The models enable Scania’s engineers to evaluate vehicle designs using the virtual simulator and test track—without, of course, building an actual test vehicle. They first test the model by exciting selected points using the simulated test rig. If the model performs well on the test rig, they add wheels and simulate the model running over a 3-D road.

Scania engineers have been able to achieve simulated results within 5% of physical measurements on the test rig and within 20% of physical measurements on the virtual track. The 20% is a reasonable margin of accuracy because of the difficulty of accurately modeling tires and interconnecting parts.

Once engineers have validated the vehicle model, they can use it to evaluate handling and driver comfort. They apply loads to various components

A virtual model of a Scania truck tractor constructed in MSC Software’s Adams/Car multibody dynamics analysis software. Scania engineers used models of truck components, test equipment, and the test track to simulate the behavior of custom-configured trucks to ensure optimal performance.

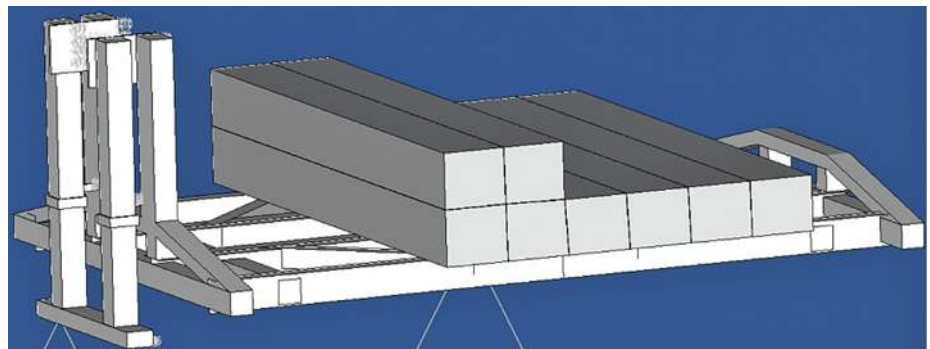

Image shows how Scania engineers use virtual models of truck components to test specific systems. Engineers are applying a load, in the form of weights, on a model of a trailer frame to simulate how the frame design will perform.

and use the results to estimate their fatigue life.

“On a new vehicle configuration, we typically simulate the vehicle performing steering maneuvers on a flat surface to evaluate steering and handling,” Ahlström said. “We drive the vehicle over a number of different road obstacles and study the vehicle behavior and driver experience.”

Simulation enables Scania to evaluate vehicle performance under very demanding conditions that would be difficult to duplicate with physical testing. Simulations also generate loads on the components that can then be used for stress analysis or fatigue life analysis. Finally, engineers perform failure mode analysis, simulating failure of major systems and their effects on driveability.

Modifications can be done easily in the virtual world, which saves a significant amount of time and money in the design process. Modifications that could cost tens of thousands of dollars using Scania’s

previous testing regime are essentially free in simulated environments.

“Adams/Car helps us understand how the multiple moving parts of the chassis interact with each other and their environment,” Ahlström said. “This knowledge helps us to identify potential problems early in the design process and make corrections on the virtual model at a much lower cost and in less time than would be required to correct the physical truck. Simulation helps encourage innovative design methods because engineers can easily explore alternative design concepts in very little time or expense. As a result, we have made significant improvements in handling and comfort of many of our designs. We have also reduced stress levels in many parts, resulting in improvements in component life.”

Chris Baker, Product Manager for Adams and Easy5 at MSC Software, wrote this article for SAE Magazines.

Doosan DX140LCR excavator features reduced tail swing

Doosan has added more power, performance, and speed to the 16-ton (14.5-t) excavator market with the T4 Interim DX140LCR-3, providing greater capabilities for site development, commercial construction, and highway/street development projects. The DX140LCR-3 excavator is a reduced tail swing machine that offers reduced machine length and added maneuverability.

selectable work modes permit operators to get maximum efficiency and fuel economy in specific applications. A maximum speed of 2.9 mph (4.7 km/h) for the excavator provides more efficient movement around jobsites.

A straight travel pedal is available for the DX140LCR-3. This new option streamlines the travel and transport of the machine. It is particularly suitable for



Doosan has added more power, performance, and speed to the 16-ton (14.5-t) excavator market with the T4 Interim DX140LCR-3, providing greater capabilities for site development.

The tail swing radius on the DX140LCR-3 is 5 ft (1.5 m), which results in a tail swing overhang of 9 in (230 mm) over the side of the machine, making it suitable for working in congested jobsites such as streets, highways, and rail lines without blocking traffic in adjacent lanes or tracks. Reduced tail swing also minimizes the potential for machine damage when working close to buildings or walls.

The DX140LCR-3 features an electronic power optimizing system that provides optimum power and fuel efficiency via four work modes, auto-idle, and machine diagnostics. Operators can work more effectively with multiple operating modes, easy-to-read display monitors and precise control levers. The

straightforward and backward travel common in trenching applications, as it provides a single foot pedal in the right-front corner of the cab floor that operates both tracks.

Doosan continues to focus on operator comfort with enhancements inside the roll-over protective structure (ROPS) cabin. Both a height lever and tilting function were added to the air suspension heated seat to allow the operator to find an optimum seating position. The cabin mounting mechanism has been improved with a thickened dampening plate, and an internal coil spring has been added to reduce cabin vibration 20%, enabling operators to work longer days with less fatigue.

Jean L. Broge

ABB 'flash charges' electric bus in 15 s

ABB has developed a new boost-charge technology that will help power what it claims is "the world's first" high-capacity, flash-charging electric bus system, with no overhead cables necessary. The Zurich, Switzerland-based power and automation technology company announced at the International Association of Public Transport congress in early June in Geneva that it is working together with the city's public transport company (**TGP**), the Office for the Promotion of Industries and Technologies (OPI), and the Geneva power utility **SIG** on the TOSA (Trolleybus Optimisation Systeme Alimentation) electric bus system pilot project.

The new boost-charging technology will be deployed for the first time on a large-capacity electric bus that can carry up to 135 passengers. The bus will be charged directly at certain stops with a 15-s energy boost, based on a "new type of automatic flash-charging mechanism" according to ABB, while the passengers enter and leave the bus. Rapid battery charging takes place at every third or fourth bus stop along the pilot project's route, which runs between Geneva airport and the city's international exhibition center, Palexpo.

Charging stations of different sizes are available to suit the specific bus stop.

"Through flash charging, we are able to pilot a new generation of electric buses for urban mass transport that no longer relies on overhead lines," Claes Ryttoft, ABB's acting Chief Technology Officer, said in a statement announcing the technology. "This project will pave the way for switching to more flexible, cost-effective, public transport infrastructure while reducing pollution and noise."

The flash-charging technology and the onboard traction equipment used in this project were developed by ABB and optimized for high-frequency bus routes in key urban areas, carrying large numbers of passengers at peak times. Onboard batteries can be charged in 15 s with a 400-kW boost at select stops. At the end of the bus line, a 3- to 4-min boost fully recharges the batteries.

An "innovative" electrical drive system enables energy from the roof-

Rapid battery charging takes place at every third or fourth bus stop along the pilot project's route, which runs between Geneva airport and the city's exhibition center.



ABB's system uses a laser-controlled moving arm, which connects to an overhead receptacle for charging at bus shelters, instead of the usual trolley poles to overhead lines.

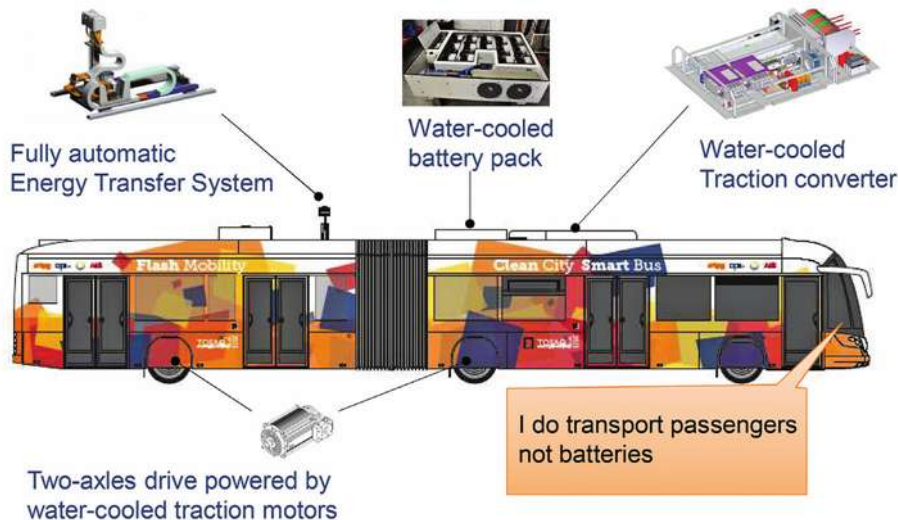

Passenger space is not compromised, with onboard equipment packaged on the electric bus' roof.



The 38-kW-h, water-cooled LTO (lithium titanate oxide) battery pack consists of 14 modules in series.

mounted charging equipment, along with the vehicle's braking energy, to be stored in compact batteries and to power both the bus and its auxiliary services, such as interior lighting.

TOSA is a zero-carbon-emissions project; the electricity used reportedly comes entirely from clean hydropower. The 15-s charging time does not interfere with the bus schedule, and the system offers aesthetic and operational benefits, too: the elimination of overhead lines not only reduces visual clutter in the urban landscape but also provides greater route flexibility.

The system uses a laser-controlled moving arm, which connects to an overhead receptacle for charging at bus shelters, instead of the usual trolley poles to overhead lines. ABB leveraged its expertise in the rail industry sector to move the technology into the public mass transportation sector.

There are two main reasons why this has not been done before, according to Bruce Warner, Electrical Engineer Research and Development at ABB. "You really need to do a quick connection, so that you don't waste time making your connection when you want to do the charging. That's been a real innovation in this project—that we've come along with something that connects more quickly than anybody else has been able to do."

The second reason is advancement in battery technology that allows fast charging, said Warner.

An ABB video offers more insight into the system's development and implementation: <http://youtu.be/c-Fg94A2Vko>.

Ryan Gehm

Deere's 2014 8R tractors get more powerful and a new cab

Deere's evolution of its 8R series tractors is apparent with its launch of six new wheel and three new track models, all with Tier 4 Final engines ranging from 245 to 370 hp (182 to 276 kW). Beside the new engine and cab improvements, additional new options include LED lights, larger wheels/tires, and increased hydraulic capabilities.

Starting with the PowerTech PSS 9.0-L engines that meet regulations with impressive fluid economy, the new 8R/8RT tractors are engineered to pro-

Nine new 8R/8RT models			
Model	Engine hp (kW)	PTO hp (kW)	Transmission
8245R	245 (183)	200 (140)	16-Sp. PST or IVT
8270R	270 (201)	225 (168)	16-Sp. PST or IVT
8295R	295 (220)	247 (184)	16-Sp. PST or IVT
8320R	320 (239)	269 (200)	16-Sp. PST or IVT
8345R	345 (257)	291 (217)	IVT
8370R	370 (276)	313 (233)	IVT
8320RT	320 (239)	264 (197)	IVT
8345RT	345 (257)	286 (213)	IVT
8370RT	370 (276)	308 (230)	IVT



Deere engineers increased the engine power ratings of all the new 8R models and boosted the maximum hydraulic flow capacity by 41% to 85 gal/min.

vide what Deere calls uncompromised performance in the field. Both the wheel and track models have Deere's SCR system, which builds upon the Tier 4 Interim DOC/DPF exhaust filter solution, according to Jarrod McGinnis, Division Marketing Manager for Deere.

"We've increased the engine horsepower ratings of all the new 8R models and boosted the max hydraulic flow capacity by 41% to 85 gal/min. This 8R option allows customers to operate at reduced engine speed while handling larger implements such as planters that require high, constant flow rates," said McGinnis. "And all tractors have the opportunity to be equipped with Intelligent Power Management, which

increases power and torque to maximize performance. In fact, with Intelligent Power Management on the 8370R Tractor, customers can boost engine performance to 405 horsepower."

The new 8R Tractors are available with either 16-speed Power Shift or an IVT transmission. The 8345R, 8370R, and all three track models feature the IVT as standard equipment. In addition, Group 49 rear tires are available on all wheel models, which improves traction, increases load-carrying capacity, and reduces soil compaction in the field because of a larger tire footprint.

These new 2014 models feature a new CommandARM and a Generation 4 CommandCenter. The completely rede-

signed CommandARM features improved ergonomics and integration of intuitive controls for the major tractor functions such as AutoTrac resume, throttle, transmission, SCVs, PTO, and hitch. The CommandARM comes with a 10-in 4600 CommandCenter display that swivels with the operator and can be equipped with GreenStar software such as AutoTrac. The 4600 CommandCenter Display has 800 x 600 dpi resolution, one USB port, four video inputs, and 32 GB of memory.

"Operators can customize the pages [on the display] to view the functions that are most important," said McGinnis. "It comes standard as a touchscreen display with video-streaming capabilities for remote cameras that could be attached to planters or other implements."

Other changes include a new CommandView III Cab with a 40° right-hand swivel operator's seat, which gives operators a more comfortable unrestricted view to the rear of the tractor and implements. Other features include the choice of optional ActiveSeat or Active Hydro-pneumatic Cab Suspension Plus, the cab suspension system that automatically adjusts ride quality based on terrain and operator preference. New 8Rs also come with an optional refrigerator to the left of the operator's seat.

"We've designed the new CommandView III Cab with laminated glass, a strategically placed insulation barrier, and an optional carpet floor mat to reduce noise and vibrations," said McGinnis. "Other enhancements include



The completely redesigned CommandARM features improved ergonomics and integration of intuitive controls for the major tractor functions such as AutoTrac resume, throttle, transmission, SCVs, PTO, and hitch.

additional sunshades, window wipers, and improved key location, which are complemented by the swivel seat to make it a quieter and more comfortable work environment.”

Track models feature configuration options capable of meeting a wide variety of operations and row spacings. These new track tractors are enhanced with the same engine, cab, control, and technology features highlighted with the

wheel models. Both the 8Rs and 8RTs come with JDLink and John Deere Farmsight capabilities for improved visibility to operational and machine data via Wireless Data Transfer and Remote Display Access.

In September 2013, Deere announced that it will be investing approximately \$40 million to create the capacity for manufacturing 8R tractors at the company's Montenegro, Brazil factory, primarily

to enhance Deere's ability to serve customers in the important Brazilian market.

“Our customers in Brazil are investing in higher horsepower tractors in the range offered by the 8R model,” said Mark von Pentz, President, Worldwide Agriculture & Turf Division. “Our decision to manufacture the 8R in Montenegro should allow the machine to be eligible for FINAME financing—the public program that targets investment in Brazil's economic development.”

Deere's history in Brazil dates from 1979 when it first invested in a joint venture in the country. In 2008, Deere announced its decision to construct the Montenegro factory to increase its capacity for tractor production in the country.

Deere builds several models of tractors at the Montenegro facility but none in the high horsepower range offered by the 8R.

Deere currently manufactures 8R tractors in Waterloo, IA, and will continue to do so for markets around the world. Deere said reconfiguration of the Brazil factory will begin later this year, and it expects to be producing 8R models in Brazil by late fall 2015. Deere said the investment in Brazil will also increase the company's use of suppliers in the region.

Jean L. Broge



The new CommandView III Cab features laminated glass, a strategically placed insulation barrier, and an optional carpet floor mat to reduce noise and vibrations.



2014 Sprinter gets upgrades in growing commercial van segment

The European-styled **Mercedes-Benz** Sprinter commercial van had been a stand-alone in the U.S. commercial van segment since its introduction to the North American market in 2001. But the competition's latest segment entries, namely the 2014 **Ford** Transit (see www.sae.org/mags/tbe/11653) and the 2014 **Ram** ProMaster (see www.sae.org/mags/tbe/11779), have changed the landscape.

"We are no longer the oddball," Claus Tritt, General Manager of Commercial Vans for Mercedes-Benz USA, said about the

stage exhaust gas turbocharger system.

The four-cylinder diesel engine, which also will power the Mercedes-Benz GLK luxury compact SUV and the E-Class AWD sedan in the U.S., will be mated to a seven-speed automatic transmission. The powerplant's clean diesel technologies include an exhaust gas recirculation system with two-stage cooling, an SCR (selective catalytic reduction) catalyst, as well as a diesel particulate filter.

According to Walther Bloch, Mercedes-Benz USA's Department Manager for Sprinter Engineering

in part to meet European criteria for pedestrian protection. "The hood was raised, and the whole front end was increased by approximately 60 mm," Bloch said, referencing the more upright stance of the grille, the lower airdam, and new designs for bumper, headlamps, and fenders.

Interior revisions include a new ergonomic steering wheel, a different seat cover fabric, and a new standard audio head unit featuring a 5.8-in color display screen with Bluetooth connectivity, USB connection, auxiliary input, and iPod integration. A **Becker** Map Pilot navigation unit is a new optional feature. The Map Pilot box can be removed, so fleet owners can switch the navigation unit from vehicle to vehicle.

The van can be fitted with various advanced safety technologies, including collision prevention assist, blind spot assist, highbeam assist, and lane-keeping assist. Those four features, which have been available on select Mercedes-Benz light-duty passenger vehicles, are new to the Sprinter and are available as optional equipment.

Sprinter can be configured as a crew van, passenger van, cargo van, cab chassis, or minibus.

The crew van and passenger van—both with 8550 lb GVWR—are available in two wheelbases and two roof heights. The cargo van is available in three body lengths, two wheelbases, and two wheelbases with GVWRs of 8550 lb, 9990 lb, and 11,030 lb.

The cab chassis with a GVWR of 11,030 lb is offered in two wheelbases. The minibus, which offers as many as 18 seats, is offered in a single wheelbase with a GVWR of 11,030 lb.

Start of production for the 2014 Sprinter is slated for July 2013 with U.S. sales targeted for the fall of 2013. Pricing for the commercial van will be announced at a later date.

Kami Buchholz



The 2014 Mercedes-Benz Sprinter has up to 547 ft³ (15.5 m³) of cargo capacity, up to 5415-lb (2456-kg) payload capacity, a step-in height starting at 19.9 in (505 mm), and a turning radius of 54.6 ft (16.6 m). Approximately 75% of Sprinters are sold with upfitter modifications.

Sprinter during a media briefing at the automaker's Ann Arbor, MI, technical center on May 6.

Tritt said the Sprinter is a benchmark vehicle and that designation "comes with obligations." A prime obligatory is improving the product, and the 2014 Sprinter's upgrades include a new standard engine, interior revisions, and the availability of advanced safety technologies.

The 2014 Sprinter offers two engine choices. The van's new standard engine is a 2.1-L four-cylinder diesel engine producing an estimated 161 hp (120 kW) at 3800 rpm and 265 lb-ft (359 N-m) between 1400-2400 rpm. It uses a 2000-bar (29-ksi) piezo injection system and a two-

Support at the NAFTA Regional Upfitter Center in South Carolina: "This is the latest revision of an engine that has been used for a couple of years in Europe on different vehicle applications."

Compared to the optional 3.0-L V6 turbodiesel that produces 188 hp (140 kW) at 3800 rpm and 325 lb-ft (441 N-m) between 1400-2400 rpm, the four-cylinder turbo-diesel achieves an up to 18% improvement in fuel economy. The V6, which mates to a five-speed automatic transmission, had been the Sprinter's lone engine offering. Since the 2010 model year, the V6 has had SCR technology.

Sprinter's exterior alterations are front-end concentrated and were done

COMPANIES MENTIONED

ABB.....	90	Deere & Co.....	46, 92	KAI.....	77	Scania.....	88
Aernnova Group.....	12	Defiance Technologies.....	11, 12	Kalinga Institute of Social Sciences.....	11	SENER.....	43
Airbus.....	69, 75	Defiance Testing & Engineering Services.....	12	KIIT University.....	10	SGL.....	33
Alcan Engineered Products.....	70	Delhi Metro Rail Cooperation.....	61	Kubota Tractor.....	87	Sharda Motor Industries Limited.....	14
Alenia.....	77	Delphi.....	64	Lego.....	56	SIG.....	90
All Nippon Airways.....	77	Dodge.....	32	LMS.....	44	SMS Mevac.....	12
Altair.....	11	Doosan.....	90	Lockheed Martin.....	71, 77	Snecma.....	24
Amrita School of Engineering.....	11	Dow Automotive.....	32	Mahindra Aerospace.....	12	Society of Indian Automobile Manufacturers.....	4, 60
Anand Automotive Systems.....	14	Eaton.....	46	Mahindra & Mahindra...4, 10, 11, 14, 47		Spicer India.....	14
ANSI.....	80	Eicher Motors.....	14	Manitex.....	79, 80	Sri Venkateshwara College Of Engineering.....	11
ARAI.....	10, 11	Element Materials Technology.....	26	Maplesoft.....	84	Sukhoi.....	74
Ashok Leyland.....	12	Eurocopter.....	76	Maruti.....	61	Tata Motors.....	11, 56, 64
Audi.....	32, 57	European Telecommunications Standards Institute.....	28	Maruti Suzuki India.....	10	Tata Steel.....	12
Auto Skills Development.....	49	Evonik.....	32	MathWorks.....	84	TE Connectivity.....	80
AVIC.....	75	Exova.....	12	Mercedes-Benz.....	94	TGP.....	90
AVL.....	46	FAA.....	76	MIT-RCF.....	34	Toho Tenax.....	32
BAE Systems.....	71	Federal-Mogul.....	38	Mitsubishi.....	76	Toray.....	33
Bajaj.....	11	Federation of Motor Sports Clubs of India.....	11	MMRTC.....	11	Toyota.....	32, 58
Becker.....	94	Ford.....	16, 32, 94, 96	Modelon.....	84	Toyota Boshoku.....	14
Beechcraft.....	29	Frost & Sullivan.....	32	Morgan Stanley.....	58	Toyota Boshoku Asia Co., Ltd.....	14
Bernstein Research.....	58	Garmin.....	29	MSC Software.....	89	Toyota Boshoku Relan India Private Limited.....	14
BMW.....	32	GE.....	24	National Board of Electric Mobility.....	55	TRAKTION Management Services.....	4, 11, 54
Boeing.....	69, 75	General Motors.....	16, 32, 18	National Composites Center.....	33	Unifi.....	30
Bombardier.....	70, 75	Georg Fischer Automotive.....	36	Nissan.....	56	United Nations.....	62
Bosch.....	11	GKN Aerospace.....	72	NSDC.....	11	U.S. Air Force Research Laboratory.....	26
Canadian General-Tower.....	30	Grede Holdings.....	35	Opel.....	16	USCAR.....	32
Car 2 Car Communication Consortium.....	28	Henkel.....	32	Politecnico di Torino.....	40	UTC Aerospace Systems.....	75
CASA.....	77	Hinduja Group.....	12	Pratt & Whitney.....	77	Vauxhall.....	16
Caterpillar.....	22, 80, 83	Hindustan Aeronautics.....	77	Ram.....	94	VE Commercial Vehicles.....	14
CFM.....	24, 75	Honeywell.....	79, 80	Relan Group.....	14	Volkswagen.....	27, 56
Chevrolet.....	18	Huntsman.....	33	Renault.....	56	Volvo Group.....	14
Chrysler.....	33	Hyatt.....	56	Reuters.....	56	World Health Organization.....	61
Comac.....	75	Hyundai.....	83	Reva.....	55	Zoltek.....	33
Composite Impulse.....	32	Indian Institute of Technology.....	62	Ricardo.....	83		
Constellium.....	70	India Pistons.....	4, 50	Rockwell Collins.....	29		
Continental.....	46	International Energy Administration.....	18	Rolls-Royce.....	72		
Continental Structural Plastics.....	32	International Standards Organization.....	30, 80	Romax.....	85		
Cummins.....	21	IPTN.....	77	RWTH Aachen University.....	33		
Curtiss-Wright.....	29			SAEINDIA.....	4, 6, 10, 11, 46, 54		
Dacia.....	56			SAE International...4, 6, 8, 10, 18, 21, 22, 30, 46, 54, 67, 80, 83, 96			
Dana Holding Corp.....	14						
Datsun.....	56						

AD INDEX

Advertiser Name.....	Page.....	Website Address
Allegro MicroSystems LLC.....	13.....	www.allegromicro.com/camp891
Altair Engineering Pvt Ltd.....	7.....	www.altair-india.in
Ashok Leyland.....	19.....	www.ashokleyland.com
AVL India Pvt Ltd.....	37.....	www.avl.com/electrification
Brakes India Limited.....	41.....	www.brakesindia.com
Celanese.....	Cover 4.....	www.celanese.com/engineeredmaterials
Comsol Inc.....	3.....	www.comsol.co.in/introvideo
Mahindra & Mahindra Ltd.....	25.....	www.mahindraxuv500.com
Mentor Graphics.....	Cover 3.....	www.mentor.com/automotive
Michelin.....	15.....	www.michelin.in
Molex Incorporated.....	Cover 2.....	www.molex.com/me/mx150.html
Smalley Steel Ring Company.....	31.....	www.smalley.com/getcatalog
TAFE.....	9.....	www.tafe.com
The Lubrizol Corporation.....	5.....	www.lubrizol.com/successtogether

Q&A



Jim Buczkowski, SAE International's Cross-Industry Standards Adviser for Vehicle Electronics & Innovation Integration: "There are certain standards in the consumer electronics business that we in automotive don't have to completely reinvent, as long as they're applied to certain areas of the vehicle that are connecting to consumer-electronics-related products."

Finding common ground among automotive, aerospace, and commercial vehicle electronics

The convergence of electronics technologies across the transportation sectors, and with the consumer electronics industry, brings challenges and opportunities to product and standards development. Jim Buczkowski, SAE International's new Cross-Industry Standards Adviser for Vehicle Electronics & Innovation Integration, recently spoke with SAE Magazines Senior Editor Lindsay Brooke about the profound changes taking place. (For the full interview, please visit <http://articles.sae.org/12375>.) Buczkowski is Ford Motor Co.'s Director of Electrical and Electronics Systems and a Henry Ford Technical Fellow.

Where is the common ground between automotive, aerospace, and commercial vehicle (CV) electronics going forward?

The common point is the consumer. Electronics are allowing the consumer to blend all the facets of their life, whether it's in the car, in an aircraft, at home, and in other places. The consumer electronics industry tends to lead in terms of technology. While they don't have the risks, regulations, and the testing rigor that automotive and aerospace have to deal with—things like electromagnetic interference, for example—they set the expectations for the kinds of experiences customers want, no matter where they are.

The industry sectors have a stake in working more closely and effectively together so we can provide solutions for consumers to use portable devices more seamlessly between their various environments.

What regulatory drivers will automotive electronics face within the next 5-10 years?

The one that's the hottest right now is related to driver distraction. We get all kinds of user feedback on this. On one end of the scale are the very confident folks who say they can multi-task and will constantly push the limit on what they think is doable in the vehicle. On the other end of the scale are those who want us to keep it really simple and basic.

The auto industry is very interested in providing those experiences in a safe way. So we're going to be working hard in understanding what the safer way is. And safer is different, depending on the individual and on the driving circumstances. A straight road on a nice sunny day with no traffic is different than a twisty road on a rainy night. Technology can help us deal with these different situations by offering different levels of human-machine interface that are most appropriate.

Looking at the common HMI issues among light vehicles, aircraft, and trucks and heavy equipment, can those various industries teach each other about minimizing operator distraction?

Yes, and there are different aspects of it, too. In aircraft, there is a lot of training required before a person can get behind the 'stick' and in heavy equipment, too. But we accept the challenge: People want a lot of capability, but they want it very simple and intuitive. I don't think those two are in conflict with each other. We have learning systems that are getting smarter and algorithms that are getting better all the time. It is possible to use technology to help us have very adaptable systems that can be adjusted to match the circumstances and your capabilities. We just have more work to do to really figure these out and refine them. It's not a question of just eliminating a lot of features and functionality in order to minimize distractions.

How might engineers in the three industry sectors collaborate on this?

There is a lot starting on the far end of the research side. There is a lot of work and opportunity in terms of human performance and understanding of cognitive loading, among other areas. There are still a lot of unknowns. There are certainly opportunities in workload management and operator fatigue. In the aircraft industry, they have to deal with pilot fatigue.

In terms of electronics standards, what are the key areas for industry collaboration?

Interoperability is always very important. Cars are no longer in isolation; we have to constantly consider V2V and V2I communication. Our products need to talk to our competitors' products, as well as to the surrounding infrastructure around the world. While we have to work through proprietary issues, standards will allow us to share across the industry.

But it's a lot more than just a bunch of logical engineers getting together and saying 'this is the way it's going to be.' It will take a broad understanding of regional needs around the world. The challenge is to agree on something quickly. 

Connected Engineering™ for the Automotive Industry

Embedded
Software

PCB Systems Design
& Mechanical Analysis

In-vehicle
Infotainment

**Electrical
Distribution
Systems Design
& Harness
Engineering**

Mechatronics
Simulation

Product
Definition
& Architecture

Network
Design &
Integration

Documentation &
Troubleshooting

©2013 Mentor Graphics Corporation. All rights reserved. Mentor Graphics is a registered trademark of Mentor Graphics Corporation.

mentor.com/automotive

SHARED TECHNOLOGIES AND EXPERTISE - The complexities of designing and manufacturing vehicles today require advanced tools that are not only proven – but interconnected. Connected Engineering™ tools from Mentor Graphics span domains in automotive, commercial vehicle, and off-highway industries. Whether it's electrical systems design, in-vehicle infotainment, mechanical analysis, or embedded software development, Mentor has the tools to help you speed design and implementation while reducing costs and improving overall quality.

**Mentor
Graphics®**

For further information or queries kindly contact: Mentor Graphics Sales and Services Pvt. Ltd.
Salarpuria Touchstone, Sy. No 15/1A & 14 Kadubeesanahalli, Varthur Hobli, Outer Ring Road, Bangalore-37
Ph +91-80-30514000 • Email : mgss_auto@mentor.com

Reinventing Transportation with High-Performance Engineered Materials



Manufacturers are under pressure to reduce weight, reduce cost and increase fuel efficiency. The use of high-performance engineered materials is helping manufacturers maintain margins as costs and competition increase. With 50+ years of technical and application development expertise in engineered materials, Celanese is uniquely positioned to help customers develop innovative products and solutions to meet these challenges.

New Extrudable Hostaform® POM



New Hostaform POM XT and PTX series set a benchmark for cold impact resistance, weldline strength and fuel resistance. These new POM grades provide low moisture absorption, excellent mechanical and tribological properties, plus high-level chemical resistance and fuel resistance. Hostaform POM XT and PTX can be extruded into flat and corrugated tubes for fuel, pneumatic braking systems, clutch, fresh air vent and sheathing applications.



Next-Generation High-Impact Hostaform POM

The Hostaform S 936X series brings new levels of performance previously unavailable in conventional impact modified POMs, delivering up to 75% improved impact performance and up to 300% increase in weldline strength. Its superior properties make it an excellent alternative for PA11-PA12 in fuel line clips, gears and other components.



Lightweight Structural Parts

Celstran® thermoplastic composites offer an unparalleled combination of stiffness and toughness, delivering outstanding value in parts consolidation, weight reduction, sound dampening and metal replacement. A wide range of resins, fibers and additives are available to help develop new product solutions with extended material property ranges.



Brilliant Solutions with Plastic

MetaLX™ metal-effect polymers combine the look of metal with the design freedom of plastics, while reducing costs and eliminating chemical pollutants associated with painting and plating. MetaLX polymers allow the efficient design and application of one-piece configurations with internal features that would be difficult or impossible to produce in metal. The MetaLX polymers are available in Hostaform acetal copolymer (POM), Celanex® PBT and Riteflex® TPC-ET.



Performance in High-Temperature Powertrain Applications

Fortron® PPS is perfectly suited for applications requiring high-temperature performance, broad chemical resistance to automotive fuels and fluids, superior dimensional stability and excellent creep resistance. Fortron PPS has a high continuous-use temperature up to 240°C, no known solvent up to 200°C and can provide potential weight savings up to 50% versus metals.



Global Performance. Global Products. Global Solutions.

At Celanese, we're much more than engineered materials. We provide total solutions with global reach, local resources, design and application development support, and deep technical knowledge.



For more information in India email: Sugam.Kulkarni@celanese.com or call +91-22-66112005

Engineered Materials

- Celanex® PBT
- Hostaform®/Celcon® acetal copolymer (POM)
- Celstran®, Compel® and Factor® LFRT
- Celstran® CFR-TP
- Fortron® PPS
- GUR® UHMW-PE
- Impet® PET
- Riteflex® TPC-ET
- Thermx® PCT
- Vandar® polyester alloy (PBT)
- Vectra® and Zenite® LCP

Copyright © 2013 Celanese or its affiliates. All rights reserved.

celanese.com/engineered-materials

Published by : SAEINDIA, 1/17, 3rd Cross, Kasturba Nagar, Adyar, Chennai – 600 020.
Printed at : Hi-tech Offset Private Ltd., 11, Srinivasa Nagar Main Road, Koyambedu, Chennai – 600 107.